



# Solutions Portfolio

Complete Quality Management

2025



**SUN NUCLEAR**  
A MIRION MEDICAL COMPANY

# Better Quality Management. Better Care.

Sun Nuclear provides the broadest range of advanced Patient Safety solutions.



**SunSCAN™ 3D**  
Next-Generation Cylindrical  
Water Scanning System  
See pgs. 36-38 for details.

Sun Nuclear Overview ..... 4  
 Independence ..... 6  
 SunServices™ ..... 8

**SunCHECK® Platform**

Platform Overview ..... 10  
 SunCHECK® Patient ..... 12  
 PlanCHECK™ ..... 13  
 DoseCHECK™ ..... 13  
 PerFRACTION™ ..... 14  
 SunCHECK® Machine ..... 16  
 SNC Machine™ ..... 17  
 SunCHECK® Machine  
 Phantoms ..... 18  
 SunCHECK® Device  
 Integration ..... 19

**Patient QA Solutions**

ArcCHECK® ..... 21  
 MultiPlug™ ..... 22  
 CavityPlug™ ..... 22  
 MapCHECK® 3 ..... 22  
 PlanIQ™ ..... 23  
 IVD™ 2 / rf-IVD™ 2 ..... 23  
 SRS MapCHECK® ..... 24  
 AVa™ Phantom ..... 24

*See also StereoPHAN™ (pg. 27) and  
 MultiMet-WL Cube (pg. 27).*

**Machine QA Solutions**

StereoPHAN™ ..... 27  
 MultiMet-WL Cube ..... 27  
 STEEV™ Phantom ..... 28  
 SRS MR Distortion Phantom ..... 28  
 IC PROFILER™ ..... 29  
 Quad Wedge Plates ..... 29  
 Daily QA™ 3 ..... 30  
 Solid Water® HE ..... 30  
 Dynamic Thorax Phantom ..... 32  
 XSight® Lung Tracking  
 System Kit ..... 32  
 Enhanced Dynamic Platform ..... 32  
 TomoDose™ ..... 33  
 Daily ISO™ Phantom ..... 33  
 RapidCHECK™ ..... 34  
 Advanced Electron  
 Density Phantom ..... 34

**Dosimetry Solutions**

SunSCAN™ 3D ..... 37  
 SunDOSE™ Software ..... 38  
 Mini-Lift Table ..... 38  
 Reservoir ..... 38  
 SunSCAN™ TPR ..... 38  
 Reference Detector ..... 39  
 ATOM® Phantom Family ..... 39  
 1D SCANNER™ ..... 40  
 PC Electrometer™ ..... 40  
 EDGE Detector™ ..... 41  
 SNC125c™ ..... 41  
 SNC350p™ ..... 42  
 SNC600c™ ..... 42

**Diagnostic QA Solutions**

Doppler Ultrasound Phantoms ..... 45  
 B-Mode Ultrasound Phantoms ..... 45  
 CT ACR 464 Phantom ..... 46  
 IQphan™ ..... 46  
 RapidCHECK™ ..... 46  
 Multi-Energy CT Phantom ..... 47  
 Mercury 4.0 Phantom ..... 47  
 CTDI Phantoms ..... 48  
 CT Perfusion Phantom ..... 48  
 AAPM CT Performance  
 Phantom ..... 48  
 Stereotactic Needle Biopsy  
 Phantom ..... 49  
 Multi-Modality Breast Biopsy  
 and Sonographic Trainer ..... 49

Image Guided Abdominal  
 Biopsy Phantom ..... 49  
 DBT QC Phantom ..... 50  
 Mammo FFDM™ Phantom ..... 50  
 Mammo CESM™ Phantom ..... 50  
 Mammo 156™ & 156D Stereo™  
 Phantoms ..... 51  
 Mammo 3D Performance Kit ..... 51

**Supporting Solutions from  
 the Mirion Portfolio**

Instadose®VUE ..... 53  
 RDS-Med™ Survey Meter ..... 54  
 RDS-Med™ Alarm Box ..... 54  
 DMC 3000™ Dosimeter ..... 55  
 ConnectStudio™ Software ..... 55

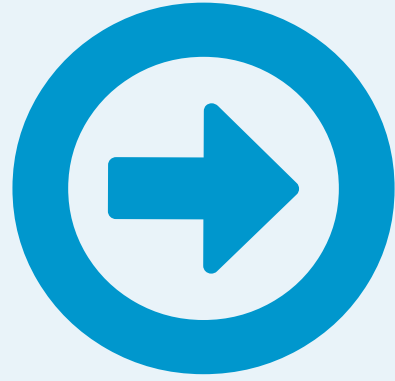

# Trusted.

## Hospitals & clinics worldwide choose Sun Nuclear.

Linac manufacturers, imaging manufacturers, researchers, and scientific associations leverage Sun Nuclear solutions routinely, too. Collectively, the fields of Radiation Therapy and Diagnostic Imaging count on us to help:

- Mitigate errors
- Reduce inefficiencies
- Validate technologies and techniques
- Elevate clinical care

Through 40 years of service, we have come to know Quality Management from all angles – and we're proud of the unique role we play in protecting Patient Safety.

Today, Sun Nuclear is stronger than ever as the cornerstone of Mirion Medical, a growing division within Mirion.

Mirion Medical innovations power the fields of Radiation Therapy QA, Diagnostic Imaging QA, Occupational Dosimetry, Nuclear Medicine and Medical Imaging Tables and Accessories. Comprised of brands and product lines including Sun Nuclear, ec<sup>2</sup> Software, Dosimetry Services, Capintec and Biodex, the Mirion Medical group is dedicated to offering healthcare practitioners and patients a safer, more efficient healthcare experience -- in pursuit of The Science of Better.

Learn more: [mirion.com/medical](http://mirion.com/medical)

### 40

Years Serving the Radiation Oncology and Diagnostic Imaging Fields

### 130+

Countries with Sun Nuclear Solutions

### 6,000+

Worldwide Cancer Treatment Facilities Use Sun Nuclear Solutions

### >90%

of U.S. Cancer Treatment Centers Use Sun Nuclear Solutions

### 20+

Countries with SunServices™ Team Member Representation





# Independence.

It's the essence of everything we do.



**Unrelenting**  
for safer, more  
effective treatments.

Independent Quality Management empowers clinical physicists to be guardians of Patient Safety, and to efficiently fulfill complex safety requirements.

**Unbiased**  
for truth in data  
and analysis.

Independent Quality Management – free from the bias of self-checking – drives accurate, standardized data analysis and redundancies essential to reducing risk.

**Unencumbered**  
to stay focused on  
catching errors.

In an expanding universe of imaging and treatment variables, independent Quality Management detects and prevents clinically relevant errors – ensuring safety is never taken for granted.

**“A critical aspect of a QA program is independence; that is, the QA procedures conducted to assure the quality and accuracy of the product or process must be independent of the product or process itself.”**

G.S. Ibbott, Journal of Physics: Conference Series 250 012001 (2010)

# SunServices™

We deliver expert support for independent Quality Management.

Through our SunServices team, Sun Nuclear provides protection for your investments in Patient Safety and your clinical program.

With deep experience across the continuum of Quality Management, we know the world in which you work – and deliver the responsiveness your department demands.



100 Support Team Members in 20+ Countries



Professional Services to Ease Technology Adoption



Onsite or Online World-Class Training



Industry-Leading Service Expertise



Our Melbourne, Florida-based 5,000 sq. ft. Training Center features a fully-functional linac bunker, lab-style classroom and large lecture hall.

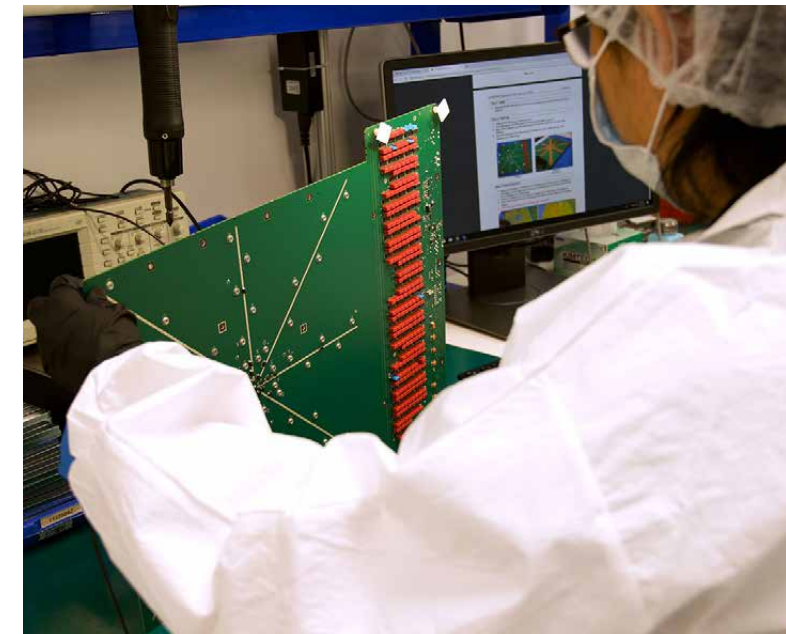

10-point Quality Service repair for Sun Nuclear solutions are available at strategically-located SunServices Centers.



# SunCHECK® Platform

## Powering Quality Management in Radiation Therapy

Scalable to meet the needs of any clinic or network, SunCHECK helps reduce risks, control costs, and improve treatment quality.



**Platform**

- One Solution for Quality Management
- Consistent and Efficient Workflows
- Seamless Clinical Integration
- Access from Anywhere



**Patient**

- Plan Quality Assessment
- Plan Checks
- Secondary Dose Calculations
- Pre-Treatment QA
- In-vivo Monitoring



**Machine**

- Daily, Monthly, Annual QA
- Measurement Device Connectivity
- Imaging, VMAT, MLC QA
- Time-savings on Routine Tasks

### Implementation Made Easy

The SunCHECK Platform can be implemented via an on-premise server or **Cloud-hosted SaaS option\***, based on your unique setup and maintenance requirements. The SaaS model is **ISO/IEC 27001:2013 certified** – assuring Radiation Therapy departments and their IT teams that SunCHECK is a robust and secure solution, with built-in backup and data redundancy.

**SunDEPLOYS™ implementation services** ensure your team achieves true workflow enhancements, and your staff is confident in bringing SunCHECK into routine use.

*\* Ask your Sun Nuclear representative or distributor about availability.*

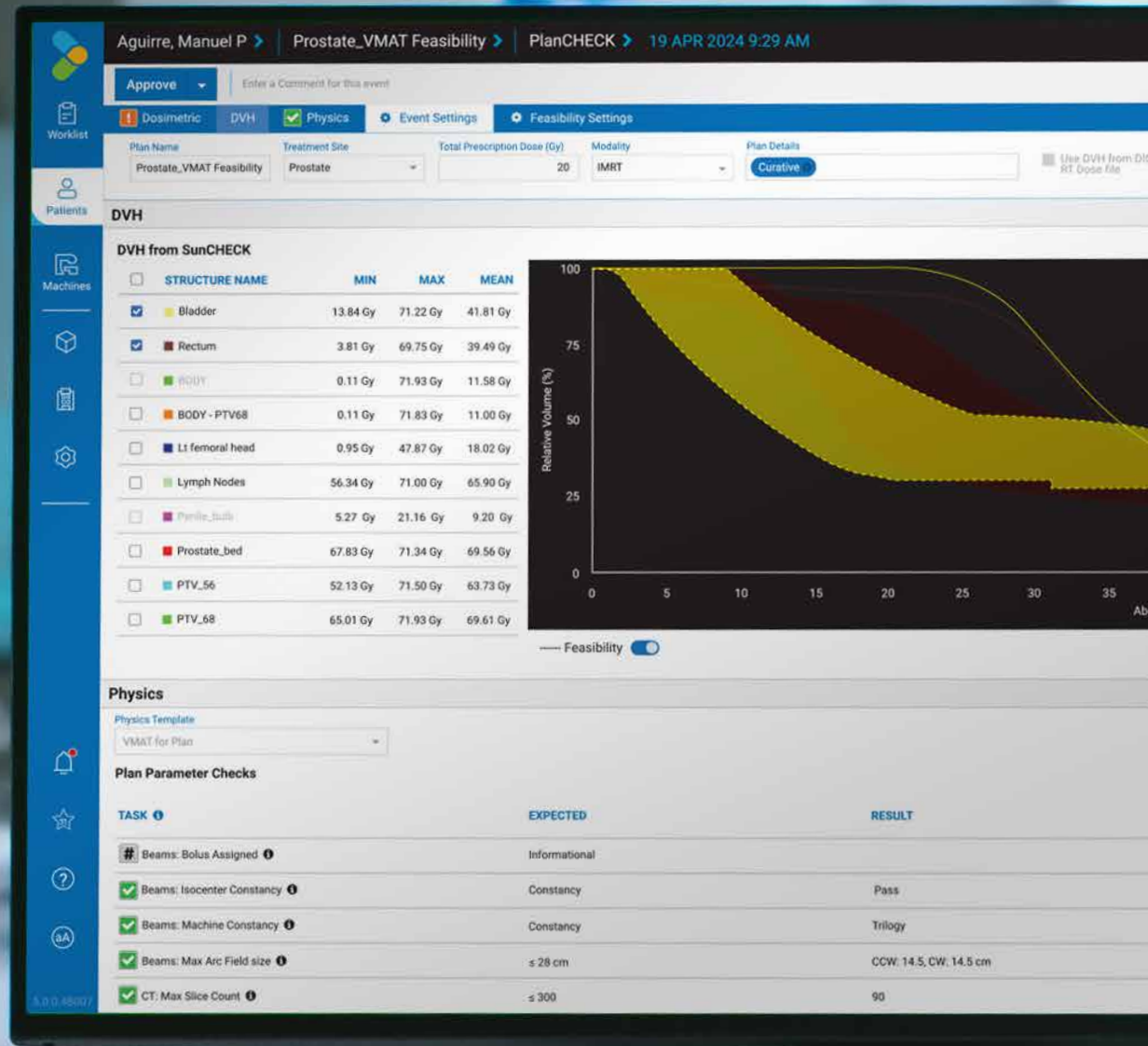

**1,500+**  
Unique Cancer  
Treatment Centers  
Globally

# SunCHECK® Patient

Independent Patient QA  
in a Single Workflow



### Purposefully Automated, yet Customizable

- Streamlines data transfer and time-consuming Patient QA tasks
- Flexible, automated analysis options, compatible with your planning and delivery technologies

### Common, Browser-Based Analysis Software

- One database across all Patient QA phases
- Ability to support Single Sign-On (SSO)/Active Directory
- Worklist-oriented dashboard
  - Overview of Patient (and Machine) QA status
  - Quick access to results, reviews, to-do's, and approvals
  - Verify successful completion of QA
- On-premise server or Cloud-hosted SaaS implementation options

### Efficient, Independent Patient QA Oversight

- Review and approve Patient QA and plans
- Physician review of results, with QA information on anatomy
- Consistent, interactive event display shows point dose, 2D analysis, 3D analysis, structure-based gammas, overall

### Specifications

Browser Support	Google Chrome (Recommended), IE11
Meets Reimbursement/Reporting Requirements	Yes
Supported Treatment Modalities	3D CRT, IMRT, VMAT, SRS and SBRT
Certification	ISO/IEC 27001:2013 for information security management, including SaaS deployment of SunCHECK

# PlanCHECK™

Plan Quality Assessment  
& Plan Checks

### Automated Treatment Plan Validation

- Assess plan feasibility and complexity for insights on meeting clinical goals and patient plan deliverability
- Assess performance versus intent
- Automate time-consuming tasks to ease burden on medical physics staff

### Software Highlights

- Automatically loads data from Varian Medical Systems® Eclipse™ and other DICOM-compliant TPSs
- Dosimetric checks compare dose/volume metrics to user-defined constraints
- Physics Checks verify treatment and non-treatment beams, and validate image and contour data

### Specifications

Treatment Planning Systems Supported	Varian Medical Systems® Eclipse™ via Scripting, others via DICOM
Physics Checks	Rules-based checks: Treatment and non-treatment beam verifications, plan parameters, structures and deliverability
Dosimetric Checks	Structure-based checks: Dose/volume metrics with user-definable constraints; complex dosimetry metrics such as Conformality Index, Conformation Number, Gradient Index and Gradient Measure for multiple structures, plus Homogeneity Index, Inhomogeneity Index and more

# DoseCHECK™

Secondary Checks

### Automated, Independent 3D Secondary Dose Calculations

- Treatment plan support for 3D, IMRT, VMAT, SRS, SBRT, Varian Medical Systems® Halcyon™ System, Accuray's TomoTherapy® and Radixact Systems, and HDR Brachytherapy
- Efficiently investigate point doses, calculated vs. planned MUs, and 3D dose displays
- Launch directly from Varian Medical Systems® Eclipse™ treatment planning system

### Specifications

Supported Systems	<ul style="list-style-type: none"> <li>• Elekta and Varian Medical Systems® Linacs, including Varian Medical Systems® Halcyon™ System</li> <li>• Accuray TomoTherapy Hi-Art®, H-Series™, Radixact® Systems, and CyberKnife® System, including Precision Treatment Planning System</li> <li>• Varian Medical Systems® and Elekta HDR Brachytherapy Systems</li> </ul>
Dose Calculation Algorithms	<ul style="list-style-type: none"> <li>• Conventional Linacs - Collapsed Cone Convolution Superposition, optional Monte Carlo</li> <li>• TomoTherapy Systems - Monte Carlo</li> <li>• HDR Brachytherapy TG-43 compliant algorithm</li> </ul>
Available Analysis & Pass/Fail Criteria	<ul style="list-style-type: none"> <li>• Photon Composite &amp; Beam Point doses, MUs*, 3D Dosimetric Analysis</li> <li>• Electron Beam Point doses</li> <li>• HDR Composite Point doses, Source Information, 3D Dosimetric Analysis</li> </ul>

\*Varian Medical Systems® and Elekta linac plans only.



**“Our Physicians regularly ask us to ‘SunCHECK’ a patient when they see something they’d like to investigate. The automated, immediate feedback on patient delivery improves our workflow...”**

Mark Young, Ph.D.,  
Chief Physicist, Providence Queen of the Valley Medical Center, U.S.

**COMING SOON**  
Varian Ethos™ Therapy and Elekta Unity Online Adaptive Secondary Dose Calculations

Varian Medical Systems® is a registered trademark, and Eclipse™ is a trademark, of Varian Medical Systems, Inc. Sun Nuclear Corporation is not affiliated with or sponsored by Varian Medical Systems, Inc.





# PerFRACTION®

Phantomless & Array-Based  
Pre-Treatment QA

In-Vivo Monitoring

### Flexible Pre-Treatment QA Analysis

- 3D measurement analysis using EPID and/or Log File data\*
- Independent Absolute Dose Analysis using EPID\*

### ArcCHECK® Direct Device Integration

- Direct device connectivity to ArcCHECK array for enhanced root-cause analysis of delivery issues

### Compliance

- Meets AAPM Task Group 218 requirements for pre-treatment QA\*\*

### Specifications

Data Sources	EPID and/or Log Files (dependent on Linac and imaging type used in delivery), and/or ArcCHECK array
Available Analysis & Pass/Fail Criteria	<ul style="list-style-type: none"> <li>• Composite and Beam Point Doses, 2D Relative Dose Analysis, 3D Dosimetric Analysis</li> <li>• 2D Absolute Dose Analysis (Transit Dosimetry Option*)</li> </ul>

### Automatically Track & Verify Dose

- Validate patient setup against the treatment plan
- Verify first fraction dose delivery vs. plan
- Review ongoing fractions

### Catch & Document Common Errors

- Anatomy issues
- Setup-related issues

### Result Analysis Options

- 3D using EPID and/or Log File data, or
- 2D through the Transit Dosimetry\* feature

### Specifications

Data Sources	EPID and/or Log Files (dependent on Linac and imaging type used in delivery)
Dose Calculation Image Set	Planning CT, Cone Beam CT
Available Analysis & Pass/Fail Criteria	<ul style="list-style-type: none"> <li>• Composite and Beam Point Doses, 2D Relative Dose Analysis, 3D Dosimetric Analysis</li> <li>• 2D Absolute Dose Analysis (Transit Dosimetry Option*)</li> </ul>

\* PerFRACTION Dosimetry

\*\* For Varian Medical Systems® non-SRS/SBRT and FFF plans

Varian Medical Systems® is a registered trademark of Varian Medical Systems, Inc. Sun Nuclear Corporation is not affiliated with or sponsored by Varian Medical Systems, Inc.

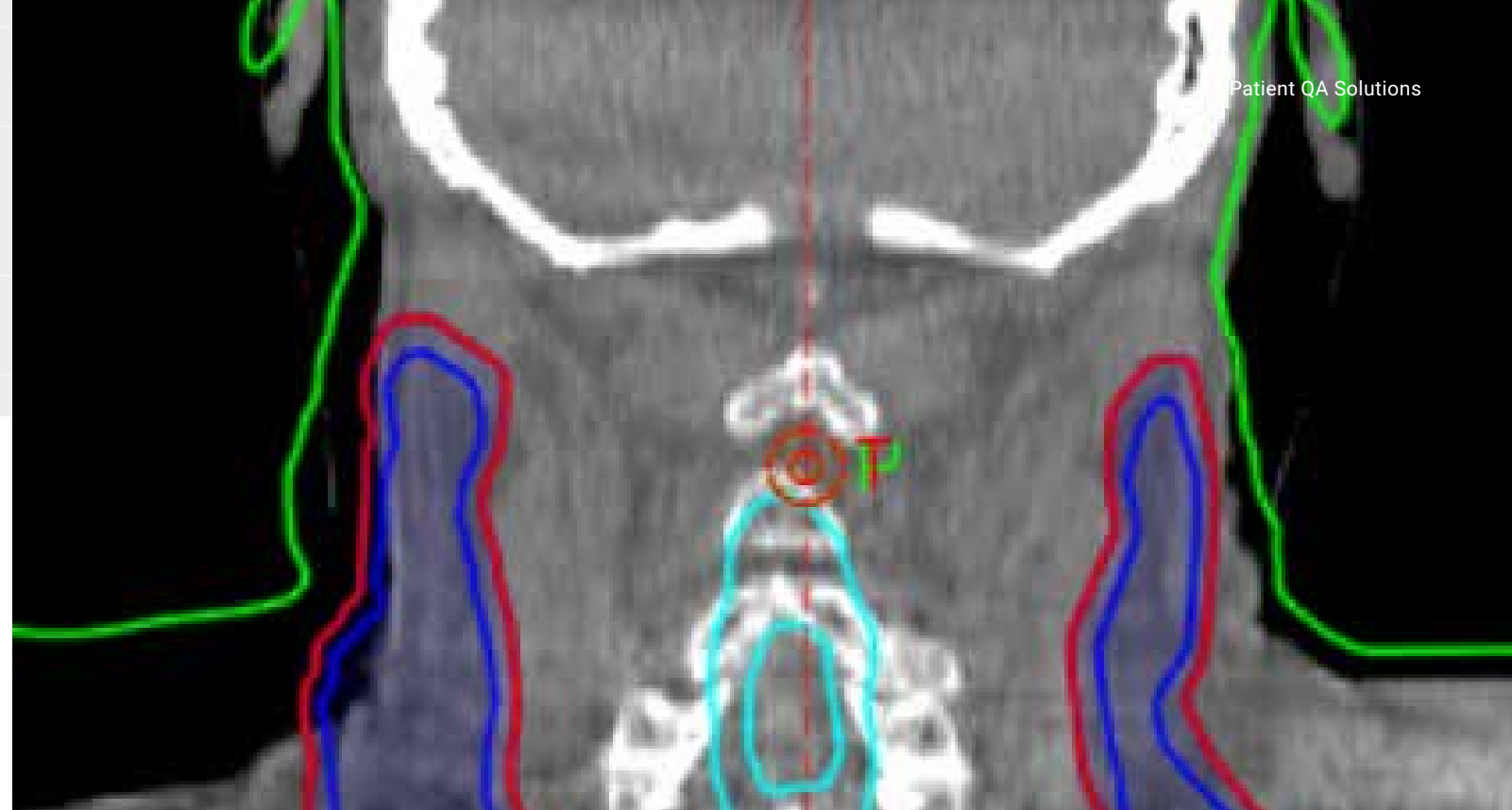

“With PerFRACTION, we’ve shown that **large-scale clinical implementation of in vivo transit dosimetry is feasible**, even for complex techniques.”

Evy Bossuyt, M.Sc.,  
Iridium Network

### An Evolving In-Vivo Program

In the first two years of one network’s in-vivo dosimetry program, errors were detected in 7% of fractions analyzed. The data drove immediate corrective actions and new departmental protocols.\*

Now, from insights uncovered over four years of their in-vivo program with SunCHECK, they have developed a process to address failed treatment fractions — leading to year-over-year decreases in failed fractions.

\*Published findings: Evaluation of automated pre-treatment and transit in-vivo dosimetry in radiotherapy using empirically determined parameters, E. Bossuyt, et al, Physics and Imaging in Radiation Oncology 16 (2020) 113–129.

Learn more about this department’s experience here >





# SunCHECK® Machine

Complete Machine QA in One Streamlined Application

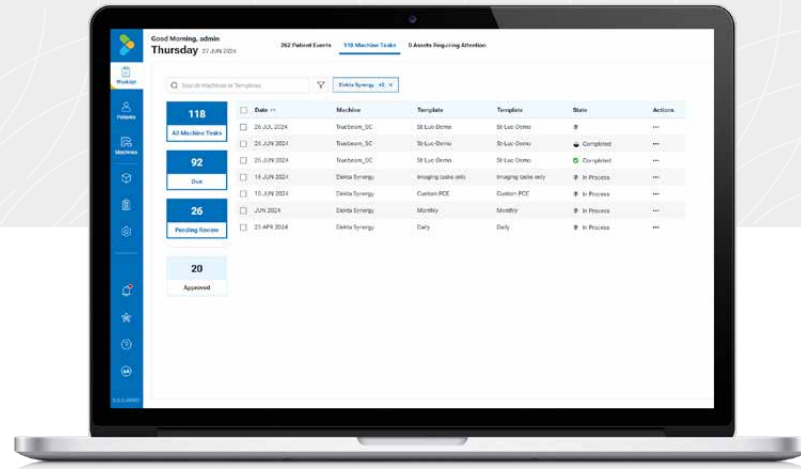

### Standardize Daily, Monthly, Annual QA

- Standardize shared tolerances among clinics, machines and staff
- Leverage ready-to-use, and customizable, QA templates

### Common, Browser-Based Analysis Software

- One database for all Machine QA
- Quickly review completed QA and drill-down into results
- Task scheduling offers quick insight on tasks coming due or overdue
- On-premise server or Cloud-hosted SaaS implementation options

### Automated Data Collection and Imaging

- Daily QA™ 3, IC PROFILER™ and IC PROFILER™-MR direct device connectivity automates data collection
- Automatic capture of QA beam delivery captures, processes and analyzes images or log files

### Easily Meet Compliance

- Complete AAPM Task-Group 142 tasks, with pre-set templates
- Meet DIN and other daily, monthly and annual QA protocols

### Specifications

Browser Support	Google Chrome (recommended), IE11
Meets Reimbursement/Reporting Requirements	Yes
Certification	ISO/IEC 27001:2013 for information security management, including SaaS deployment of SunCHECK

# SunCHECK® Machine

Daily, Monthly, Annual QA

### Standardized, Efficient Machine QA

- Share tolerances among clinics, machines and staff
- Gain efficiencies with ready-to-use, but customizable, templates
- Complete all TG-142 and DIN QA easily within SunCHECK Platform
- Asset management for linking departmental equipment to tasks
- External data import, for single source storage and reporting, including Varian Medical Systems® Machine Performance Check

### Automated Data Capture

- Automate beam measurement with direct integration to Daily QA™ 3, IC PROFILER™, PC Electrometer™, 1D SCANNER™ and IC PROFILER™-MR devices.
- Eliminate additional software needed for data transfer

### Specifications

Protocol support	<ul style="list-style-type: none"> <li>TG-142 (all 127 tests in tables 1-6)</li> <li>TG-51</li> <li>DIN</li> <li>Daily QA Support TG-66, TG-148, TG-135 and 10CFR 35</li> <li>Custom templates</li> </ul>
Direct Device Connection	1D SCANNER, Daily QA 3, PC Electrometer, IC PROFILER and Quad Wedges (Optional) and IC PROFILER-MR devices

# SNC Machine™

Imaging, VMAT, MLC QA

### Automated QA Beam Capture

- SunCHECK Machine automatically captures, processes and analyzes images or log files
- Results are stored within SunCHECK Machine for easy review/audit
- Notifications may be turned on for pass/fail status

### Imaging Phantom Support

- Supports most QA/QC Phantoms, including CT ACR 464 Phantom
- Works with Sun Nuclear MV-QA, kV-QA, FS-QA, and WL-QA Phantoms (see next page for details)

### Specifications

Imaging Test Support	<ul style="list-style-type: none"> <li>Image Quality CBCT, kV, MV</li> <li>MLC</li> <li>VMAT</li> </ul>
MLC/ Mechanical	<ul style="list-style-type: none"> <li>MLC Picket Fence, Positioning, Leaf Speed, Hancock</li> <li>Winston Lutz Radiation &amp; Machine Isocenter, Hancock</li> <li>Starshot Gantry, Couch, Collimator</li> <li>Light/Radiation Field Congruence</li> </ul>
VMAT	<ul style="list-style-type: none"> <li>Dose Rate vs. Gantry Speed</li> <li>Leaf Speed</li> <li>Arc Point Dose</li> <li>DMLC Point Dose</li> </ul>



**“Our IT group was overjoyed that we could uninstall 5 or 6 software applications and instead have only a web-based application they needed to support. They have been able to take a reduced, hands-off approach to managing the system.”**

Mark Geurts, M.S., Chief Physicist, Aspirus Health System, U.S.

Varian Medical Systems® is a registered trademark of Varian Medical Systems, Inc. Sun Nuclear Corporation is not affiliated with or sponsored by Varian Medical Systems, Inc.



# SunCHECK® Machine Phantoms

## MV-QA

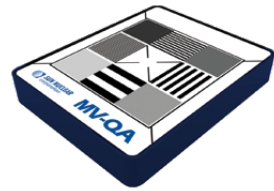

### Applications

- Image scaling, positioning offset, spatial resolution, contrast, uniformity and noise
- Easy setup, alignment clearly marked on overlay and image

MV Line Pairs (mm)	0.1, 0.2, 0.5, 1.0 ± 0.025
MV ROI	9 (4 spatial, 4 contrast, 1 center)
MV Dimensions (cm)	12.7 L x 10.2 W x 2.5 D

## kV-QA



### Applications

- Image scaling, positioning offset, spatial resolution, contrast, uniformity and noise
- Easy setup, alignment clearly marked on overlay and image

kV Line Pairs (mm)	0.6, 1.2, 1.8, 2.4 ± 0.01
kV ROI	28 (4 spatial, 23 contrast, 1 center)
kV Dimensions (cm)	12.7 L x 12.7 W x 1.6 D

## FS-QA

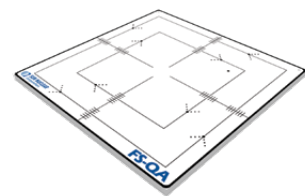

### Applications

- Symmetric and asymmetric light field/radiation field coincidence and jaw positioning
- Flatness and symmetry for photon and electron beam profile constancy

Field Sizes (cm)	10 x 10; 15 x 15
Markers (±0.1 mm)	56 - Field size (7 per field edge)
Dimensions (cm)	17.8 L x 17.8 W x 0.6 D

## WL-QA

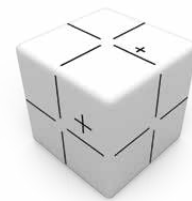

### Applications

- Winston-Lutz measurements
- Imaging and radiation field isocenter coincidence
- Cone-beam CT positioning/repositioning
- End-to-end IGRT positioning tests
- 3D isocenter offset results

Dimensions (cm)	6.0 x 6.0 x 6.0
Sphere Size (mm)	7.0
Sphere Center Accuracy (mm)	0.2

# SunCHECK Device Integration

## Connectivity & Control

The SunCHECK Platform allows full control of essential Sun Nuclear Patient and Machine QA devices, without having to launch or maintain a separate application. Automated data collection and beam measurements help streamline manual workflows.





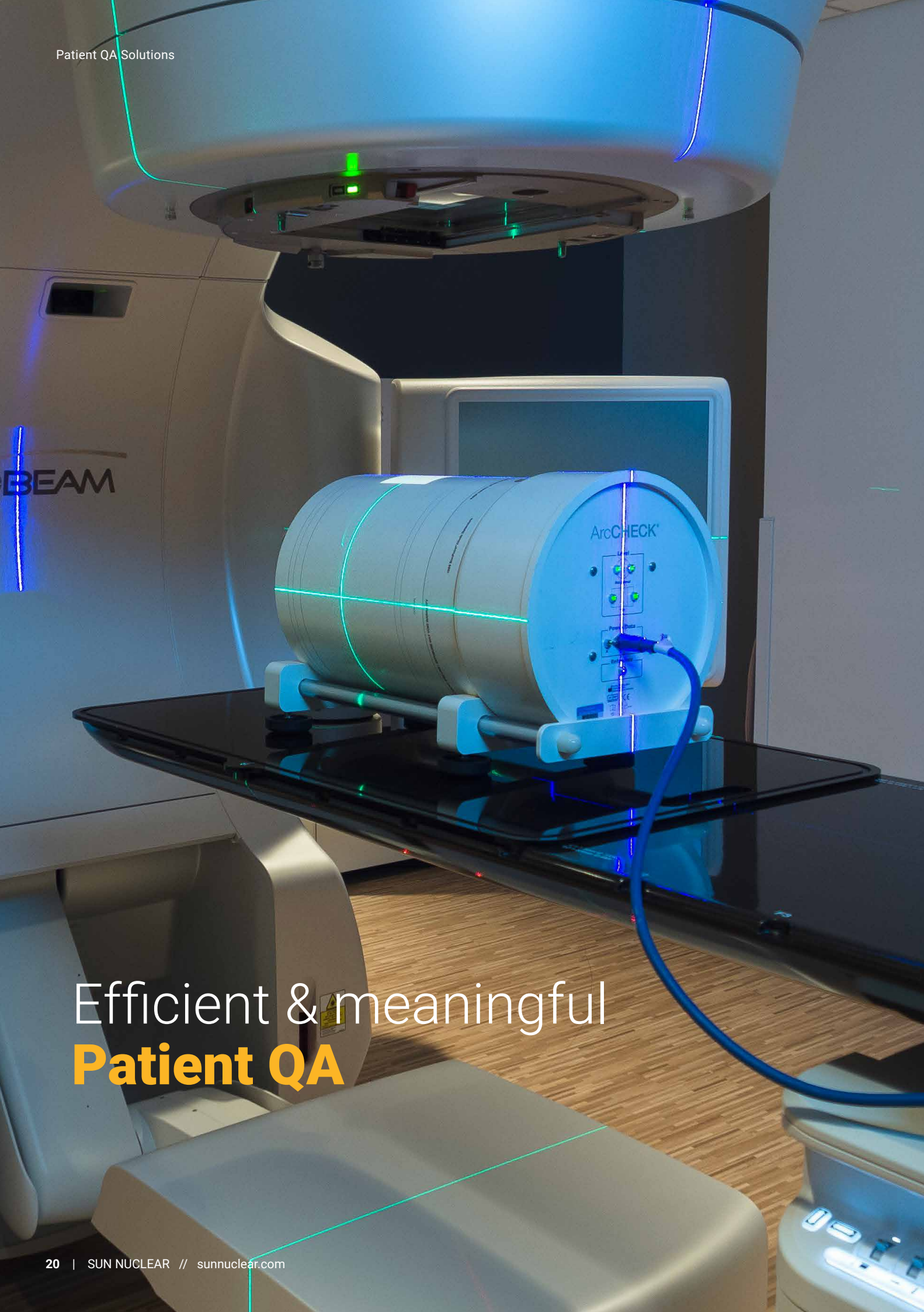

Efficient & meaningful  
**Patient QA**

## ArcCHECK®

The Benchmark for 3D Pre-Treatment QA

DIRECT  
SunCHECK™  
INTEGRATION



### Powerful Patient-Specific QA

- Recommended by AAPM Task Group 218 for 3D measurement
- Measures and correlates gantry angle, leaf-end position, absolute dose, and time
- For all modalities - IMRT, VMAT, SBRT, Tomo, Halcyon and MRgRT QA
- Works with Enhanced Dynamic Platform (as MotionCHECK™ 3D solution) for QA of systems that perform tumor tracking and dynamic delivery such as the Accuray Radixact® System with Synchrony® and breath-hold gating such as the Radixact System with VitalHold™

### Clinically Relevant Dose & DVH QA

- Identify TPS and beam delivery errors
- 1,386 SunPoint® Diode Detectors for increased BEV data density
- Angular corrections accurate to ±0.5° using the Virtual Inclinometer™
- Consistent BEV for all gantry angles measuring entrance and exit dose at multiple depths
- Real-time electrometer measures every pulse

### Software Highlights

- SNC Patient™ software compares measured dose points to planned dose points
- 3DVH® Software for full 3D QA to support beam model adjustments
- Direct connectivity with SunCHECK™ Platform for expanded pre-treatment QA

### MLC Pattern Machine QA

- Evaluate discrepancies between planned and delivered MLC patterns

 MR-compatible version available

### Device Specifications

Detector Type	SunPoint® Diode Detectors
Detector Quantity	1386
Detector Spacing (cm)	1.0, 0.7 cm Beams Eye View, 0.5 cm with Merge feature
Array Diameter (cm)	21.0
Water Equivalent Inherent Buildup (g/cm²)	3.3
Detector Physical Depth (cm)	2.9
Array Geometry	Helical Grid (HeliGrid) 1 cm offset
Phantom Material	PMMA (Acrylic)
Active Detector Area (mm²)	0.64
Detector Sensitivity (nC/Gy)	32.0
Max Dose/Pulse (Gy)	0.003
Detector Stability	0.5%/kGy at 6 MV
Dose Rate Dependence	± 1%
Update Frequency (ms)	50
Number of Connection Cables	Single power/data cable
Dimensions (cm³)	27.0 x 43.0
Weight (kg)	15.4

### Transport Option

18-inch wide trolley, designed to slide away after positioning on couch; not MR-compatible

MotionCHECK 3D system combines ArcCHECK with Enhanced Dynamic Platform for QA of motion management systems. Learn more on p. 32.





## CavityPlug™ & MultiPlug™

Tissue Equivalent Inserts for ArcCHECK®



### Flexible Interior Dose Measurements

- Support heterogeneity tests
- Tissue equivalent inserts
- Brain, breast, bone, liver, lung, muscle, adipose, titanium, and water/air

### MultiPlug

- Accepts ion chambers, stereotactic detectors and film
- Interior point measurement in 25 unique locations

### CavityPlug

- Simplified isocenter dose measurement, without the film and tissue-equivalent insert features of MultiPlug

## MapCHECK® 3

The Benchmark for 2D IMRT QA



### Built for Pre-Treatment IMRT QA

- Most detectors (SunPoint® 2 Diode Detectors) of any 2D array
- Proven stability in large active field size (26 cm x 32 cm)

### SNC Patient™ Software Highlights

- Compares dose distribution from plan file to actual measured values
- Highlights points outside acceptance criteria

### Address Rotational Beams

- Use with **MapPHAN™**, a water equivalent phantom, for helical and arc-based delivery systems

### Device Specifications

Detector Type	SunPoint® 2 Diode Detectors
Detector Quantity	1527
Field Size (cm)	26 x 32
Detector Spacing (mm)	7.07
Active Detector Area (mm x mm)	0.48 x 0.48
Active Detector Volume (mm³)	0.007
Detector Sensitivity (nC/Gy)	15
Sampling Frequency (ms)	50
Detector Stability	1%/kGy at 6 MV
Dose Rate Dependence	±1.5% over the range of 100 cGy/min to 1400 cGy/min
Inherent Buildup (g/cm²)	1.5
Inherent Backscatter (g/cm²)	2.3
Radiation Measured	Photons Co-60 to 25 MV
Number of Connection Cables	Single power/data cable
Dimensions (L/W/H)	56.0 cm x 29.2 cm x 3 cm
Weight (kg)	5.6

## PlanIQ™

Rx Feasibility & Plan QA



### Strengthen Treatment Plan Quality

- Analyze patient-specific feasibility of clinical goals
- Gain insights on areas of improvement

### Plan Quality Scoring

- Quality scores for every target and OAR
- Plan Quality Metric (PQM) score and Adjust PQM scores rate patient-specific treatment plan feasibility

### Protocols

- Choose from 70+ site-specific protocol libraries
- Leverage PQM for protocol best practices

### Compliance

- Treatment plan reports satisfy accreditation audit requirements
- Simplified peer review with shareable, interactive files
- Supports AAPM Task-Group 53 compliance

## IVD™ 2 with ISORAD™ & QED™

Easy-to-Use In-Vivo Dose Monitoring



### Uncomplicated In-Vivo Monitoring

- Wired or wireless versions
- Automatic patient temperature compensation
- QED or ISORAD detector options, with SunPoint® Diode Detectors

### Software Highlights

- Use with control module or PC software
- Networkable Microsoft SQL patient database with robust Protected Health Information (PHI) security
- Correction factor tools
- Direct export to Varian Medical Systems® ARIA® Oncology Information System

### Detectors

- Flat design for easy placement (QED); Cylindrical design for isotropic response (ISORAD)
- 3 Photon Energy Ranges, 1 Electron Range, and Skin (QED)

### Detector Module Specifications

Channels	Standard (rf-IVD 2/IVD 2) 8/4 Standard 4 Maximum 52
Repeatability	± 0.2% or ± 0.1cGy
Polarity	Bipolar (negative or positive polarity detectors)
Leakage	Automatic compensation
Calibration	User calibrated
Warm-up time (sec)	< 30
Wireless frequency (MHz)	USA 916.5; EU 433.92
Power	Rechargeable NiMH battery (12 hr) Power supply
Dimension L/W/H (cm)	7.0 x 12.0 x 3.0
Weight (kg)	0.34

*Varian Medical Systems® is a registered trademark, and Varian™, and ARIA® are trademarks, of Varian Medical Systems, Inc. Sun Nuclear Corporation is not affiliated with or sponsored by Varian Medical Systems, Inc.*

**3,390**  
Total Publications  
featuring MapCHECK®  
& SRS MapCHECK® arrays

**1,220**  
Total Publications  
featuring ArcCHECK® array

Review key findings:  
[sunnuclear.com/publications](http://sunnuclear.com/publications)

# SRS MapCHECK®

## SRS & SBRT QA, No Film



### Moving Beyond Film

- Film equivalent SRS/SBRT Patient QA for use with the **StereoPHAN™** end-to-end phantom
- Streamline your workflow from ~300 minutes to ~10 minutes

### Irradiate From Any Angle

- Accounts and corrects for angular dependence, field size, and pulse rate
- Ensures accurate dose measurement from any angle, including vertex fields

### Flexibility, Speed, & Accuracy

- Detects for output factor, MLC, and grid size errors
- Prevents more common sources of SRS/SBRT treatment errors

### Unmatched Detector Resolution

- Detector spacing and resolution specifically designed for SRS/SBRT
- Measures field sizes down to 5 mm (5 diodes in 5 mm cone)
- Supports AAPM TG-101 requirement -- SRS measurements performed with <1 mm detector

### SNC Patient™ Software

- Robust angular corrections detect and adjust for translational offset between compared datasets with precision of 0.1 mm (in line with film)
- Guidance for ideal setup of Single-Isocenter Multiple-Target (SIMT) plans (QA Setup tool)
- Offers simplified shifts for occasional larger fields
- Couch kick compatible
- Includes CyberKnife® Machine QA capabilities

### Specifications

Detector Type	SunPoint® 2 Diode Detectors
Detector Quantity	1,013
Detector Spacing (mm)	2.47
Active Detector Area (mm x mm)	77 x 77
Detector Sensitivity (nC/Gy)	15
Sampling Frequency (ms)	50
Dose Rate Dependence	+/- 1.0% (100 MU/min to 2400 MU/min)
Inherent Buildup (g/cm²)	2.75
Inherent Backscatter (g/cm²)	2.75
Modalities Supported	Static, rotational, coplanar and noncoplanar (including vertex), CyberKnife® system (including VSI and M6 models with Cones or Incise and MLC Collimators), FFF, cone and MLC fields
Radiation Measured	Photons 6 MV, 10 MV, 6 FFF, 10 FFF
Number of Connection Cables	Single power/data cable
Dimensions (L/W/H)	320 x 105 x 45 (mm)
Weight (kg)	1.9



# Stereotactic QA

Meet the stringent demands of stereotactic treatments, with our suite of SRS/SBRT solutions.

**Learn more: [sunnuclear.com/srsqa](http://sunnuclear.com/srsqa)**

# AVa™ Phantom

## SGRT Alignment Verification

### StereoPHAN™ Accessory

Comprehensive tracking for SGRT (Surface-Guided Radiation Therapy) systems

- **SGRT-visible and -trackable** surface structures
- **IGRT alignment and verification**, including offset positions
- **IGRT reference point positioning verification** with 3-Axis Off-set StereoPHAN insert



Patent-pending







Improving by measuring  
**Machine QA**

## StereoPHAN™

Comprehensive End-to-End  
Stereotactic QA



### Confident Program Commissioning

- Test all aspects of stereotactic planning and delivery
- MRI/CT image fusion, CT to linac patient alignment, and treatment planning QA
- Rotate phantom up to 360° and combine with inserts for sagittal, coronal and transverse plane measurements within 0.1 mm accuracy

### Versatile End-to-End Stereotactic QA

- Use with **SRS MapCHECK®** array for film-less, patient-specific QA for challenging small field and MLC-based SRS cases
- Use with **MultiMet-WL Cube** for multi-met single isocenter off-axis verification

### Multi-Modality Compatibility

- Supports conventional linacs, CyberKnife® devices, Varian Medical Systems® HyperArc™ Systems, vertex delivery beams, and MRgRT
- SRS headframe compatibility: Brainlab®, Fraxion®, and Leksell Gamma Knife® systems

### Specifications

Material	Polymethyl methacrylate (PMMA)
Weight (cylinder, stand, slide)	6.6 kg (15 lbs)
Measurement cubes (mm)	85 x 85 x 85
Dimensions - L/W/H (mm)	522 x 276 x 229

## MultiMet-WL Cube

Targeting Accuracy Check  
for MultiMet SRS



### Single-Isocenter Multiple-Met SRS QA

- Efficiently measures targets up to 7 cm off-axis within 0.1 mm accuracy
- Compatibility with Cone, MLC or Jaw deliveries

### User-Friendly Software

- Software identifies off-axis and rotational sources of error – Gantry, Couch or Collimator – in 6 degrees of freedom
- Optimized RT plan enables fast and clinically useful analysis of combined Winston-Lutz results

### Versatile Small-Field Tool

- Use with **StereoPHAN** and **SRS MapCHECK** solutions, or as a standalone phantom

### Specifications

Dimensions (mm)	85 x 85 x 195
Targets	6 (5 mm diameter) tungsten targets in specified locations
Target to Cross-Hair Tolerance	± 0.1 mm
Target Material	Tungsten Carbide
Quantifiable Off-Axis Accuracy Range	Up to 7 cm

## StereoPHAN™ Inserts



Film



Ion chamber



CT/MRI



MRI Signal Generator



Universal Spacer



Multi-film

See more inserts available on [sunnuclear.com](http://sunnuclear.com).



## STEEV™ Phantom

Stereotactic End-to-End Verification



### SRS Commissioning & Treatment Verification

- Meet TG-101 requirements for end-to-end SRS commissioning and QA
- Anthropomorphic, tissue-equivalent design accounts for challenging effects of tissue heterogeneity

### Accurate Patient Simulation

- Compatible with most positioning and fixation devices
- Internal details (e.g., cortical/trabecular bone, brain, spinal cord, teeth, sinuses, trachea) provide realistic clinical simulation
- Geometric and organic target inserts provide means for comprehensive image QA, geometric machine QA and TPS QA for increased confidence in system performance

### Multi-Modality Imaging & (Off) Isocenter Dose Measurements

- MRI/PET/CT inserts include: spherical target, organic targets for deformable image registration, spatial 3D distortion, ISO center
- Inserts include: TLD dosimetry, OSL dosimetry, film dosimetry, film stack dosimetry, film with fiducial, electron density, Winston-Lutz

### Specifications

Includes:

Stereotactic Radiosurgery Head

MRI/CT ISO Center rectangular insert

Brain Equivalent Spacer (63.4 x 63.4 x 10 mm)

Brain Equivalent Spacer (63.4 x 63.4 x 20 mm)

Brain Equivalent Spacer (63.4 x 63.4 x 63.4 mm)

Solid Ø 12.7 mm (posterior chamber access plug)

Solid Ø 12.7 mm anterior chamber access plug with MRI/CT fiducial

Neck Alignment Plate & Rubber Clamp

## SRS MR Distortion Phantom

Assess MR Image Distortion in SRS Planning



### Characterize Geometric Accuracy for MR use in Treatment Planning

- Assess MR image distortion in SRS planning
- Realistic anthropomorphic scenario for CT and MR imaging
- Presents simulated bony anatomy as rigid landmarks for image fusion
- Special pads compatible with all fixation frames
- CT/MR markers facilitate positioning and image registration

### Optimizing SRS QA

- Verify image fusion and deformable image registration algorithms used in various treatment planning systems
- Tissue equivalent, anthropomorphic phantom

### Distortion Check Software

- Detects physical control points (859) throughout the 3D image volume
- Cloud-based solution designed to quickly and automatically quantify distortion in MR images

### Specifications

Dimensions	32 cm x 24 cm x 18 cm
Weight	12 lbs (5.5 kg)
Materials	Skull: Plastic-based bone substitute; Interstitial/ Soft tissues: Water-base polymer; Grid: Reinforced nylon
Software	Distortion Check software
<b>Model 603-GS Includes</b>	
1	MR Distortion & Image Fusion Head Phantom
1	ABS Cradle
Unlimited	Unlimited scans using MRI Distortion Check Software for initial 2 year period
1	Custom Carry Case

## IC PROFILER™

Real-Time, Tankless Beam Scanning



### Monthly & Annual QA in Minutes

- A single measurement provides real-time beam performance data, including:
  - Constancy checks for output and beam quality
  - Flatness, symmetry, field size and penumbra width

### The Water Tank Alternative

- Accurate within 0.5% to a water tank
- Sets up in minutes, with no warm-up or pre-irradiation needed
- Linac acceptance, routine QA, and more

### SunCHECK Integration

- Direct connectivity with **SunCHECK™ Platform** for efficient Monthly and Annual QA

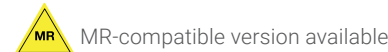

MR-compatible version available

### Device Specifications

Detector Type	Parallel plate Ion Chamber
Detector Quantity	251 total; X Axis: 63; Y Axis: 65; -Diagonal: 63; +Diagonal: 63
Detector Spacing (mm)	5.0
Array Size (cm)	32.0 x 32.0
Detector Volume (cm³)	0.046
Detector Sensitivity (pC/cGy)	14.4
Inherent Buildup (g/cm²)	0.94
Inherent Backscatter (g/cm²)	2.3
Phantom Material	PMMA (Acrylic) / PC
Weight (kg)	8.8

## Quad Wedge Plates

Simplified Beam Energy Verification

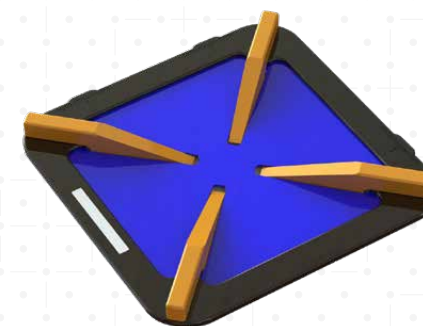

### Accelerate Beam Scanning

- Use with **IC PROFILER™** array for fast, precise energy measurements
  - Quad Wedges Plates are not suitable for use with IC PROFILER™-MR array
- Easy, reproducible setup
- Maximum efficiency compared to Solid Water (~15 minutes for 5 beams vs. ~60 minutes)

### Photon & Electron Measurement

- Supports a wide range of energies for photons and electrons

### Specifications

Electron Energy Quad Wedge Plate	Aluminum-based design; Suitable for analysis of energies from 4-22 MeV
Photon Energy Quad Wedge Plate	Copper-based design; Suitable for analysis of energies from 6-18 MV

## Daily QA™ 3

Daily Beam Quality Analysis  
in One Measurement



DIRECT  
SunCHECK™  
INTEGRATION

### Fast Daily Checks of Energy Constancy, Beam Quality

- After daily test beam delivery see results for: dose output, beam flatness, beam symmetry, beam energy, light-radiation field coincidence, shape constancy, and field size shift for FFF

### Efficient, Independent Beam Delivery Error Detection

- Daily test templates are easy for physicists to setup and handoff to therapists
- Fast and simple set up Rotational and FFF beams are supported, with no warm-up or pre-irradiation needed, and no additional trips to the vault
- Power Data Interface (PDI) managed through single-cable architecture
- Wireless option available – eliminates cable connections by using rf connections

### SunCHECK Integration

- Direct connectivity with SunCHECK™ Platform for efficient Daily QA
- Pre-configured TG-142 tests, tolerances and categories
- Safety, MLC and imaging tests reside in same database
- Connect device and data is collected automatically (no manual entry)

 MR-compatible version available

Specifications	
Detector Type	SunPoint® Diode Detectors Vented Ion Chambers
Detector Spacing (mm)	Diodes 5.0
Chamber Active Volume (cm³)	Electron 0.6; Photon 0.3
Field Size (cm)	20 x 20
Inherent Buildup (g/cm²)	Chambers 1.0 ± 0.1
Inherent Backscatter (cm)	2.3
Electron Energy Attenuation	Air, Cu, Al, Fe
Radiation Measured	Electrons, 4 MeV to 25 MeV; Photons, Co-60 to 25 MV
rf Frequency (rf-Daily QA 3) (GHz)	2.400 to 2.485
Dimensions L/W/H (cm)	25.6 x 40.8 x 4.6
Weight (kg)	5.7
Number of Connection Cables	Single power / data cable



## MR-Guided RT QA

Address the unique challenges magnetic fields present, with custom-designed QA solutions.

Learn more: [sunnuclear.com/mrqa](http://sunnuclear.com/mrqa)



## Solid Water® HE

Reliable, Durable Water  
Equivalent Phantoms



### Photon & Electron Energy Measurements

- Mimics true water within 0.5% for accurate calibration of radiotherapy beams
- Exceptional, verified slab uniformity
- 30 cm or 20 cm slab kits, designed to fit MapCHECK® 3 and IC PROFILER™ arrays, available for measuring output with a wide range of energies
- Individual slab thicknesses from 0.1 cm to 6.0 cm available

 MR-compatible

Specifications	
<b>Depth Ionization Relative-to-water</b>	
Photons	1.000 +/- 0.005
Electrons	1.000 +/- 0.005
<b>Density</b>	
Mass Density (g/cm³)	1.032 +/- 0.005
Electron Density (e⁻/cm³ N <sub>A</sub> )	0.557 +/- 0.001
Solid Water HE / Water	1.000 +/- 0.005
Electron Density Ratio	

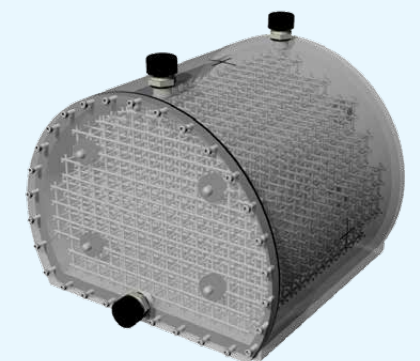



# Dynamic Thorax Phantom

Analyze Image Acquisition, Planning & Dose Delivery Verification

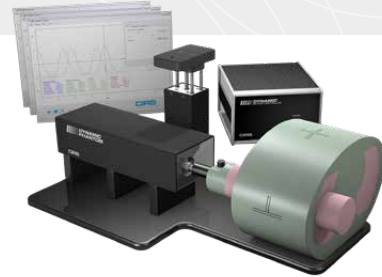

## Motion IGRT & IMRT QA

- Comprehensive analysis of image acquisition, planning and dose delivery in IGRT
- Investigating and minimizing the impact of tumor motion inside the lung
- 3D tumor motion within tissue-equivalent phantom, representing lung
- Sub-millimeter accuracy and reproducibility
- Surrogate breathing platform accommodates numerous gating devices
- A Deviceless 4D CT add-on is available for users of the Smart Deviceless 4D system from GE Healthcare

## Tissue-Equivalent Lung Phantom

- Tissue equivalent from 50 keV to 125 MeV
- Compatible with TLD, MOSFET, nanodot™, microchamber, PET/CT targets and film

## XSight® Lung Tracking Phantom Kit

- Utilizes a specialized phantom body verified and validated by Accuray for use with CyberKnife® systems
- Designed to work in conjunction with the Synchrony® motion synchronization technology

## Motion Control Software

- Enables different cycles, amplitudes and waveforms
- Graphical, intuitive user interface

### Specifications

Dimensions	67 cm x 32 cm x 28 cm (26" x 13" x 11")
Weight	17.2 kg (38 lb)
Amplitude, IS	± 25 mm
Amplitude, AP/LR	± 5 mm
Amplitude, Surrogate	± 25 mm
Motion Accuracy	± 0.1 mm
Cycle Time	1 - ∞ (adjusted based on amplitude)
Waveforms	sin (t), 1-2cos4(t), 1-2cos6(t), sawtooth, sharkfin

# Enhanced Dynamic Platform

Programmable Motion for Tracking & Positioning



## Highlights

- Works with ArcCHECK® (as MotionCHECK™ 3D solution) for QA of systems that perform tumor tracking and dynamic delivery such as the Accuray Radixact® System with Synchrony® and breath-hold gating such as the Radixact System with VitalHold™
- Builds upon the Dynamic Platform, with sub-millimeter accuracy for 3D Motion QA of systems that perform tumor tracking and gating
- Easily set up for 1D, 2D or 3D motion QA
- Inferior-superior motion up to +/- 25mm (50 mm total) for applicable phantoms up to 70 lb.
- An 11.3° inclined plane provides +/- 5.0 mm (10 mm total) of motion in posterior-anterior direction (for applicable phantoms up to 50 lb).
- 30° rotation about the linac couch provides +/- 12.5 mm (25 mm total) of lateral motion
- Surrogate platform simulates posterior-anterior chest wall motion of +/-25mm (50mm total)
- Includes Motion Control Software

### General Specifications

Dimensions (cm)	92.8(L) x 37.5(W) x 27.5(H) (for all motions at home position)
Weight (kg)	18.4
Position Accuracy (mm)	Position Accuracy ( -/+0.25 mm)
Maximum Amplitude Inf/Sup (mm)	+/- 25.0 (50 total)
Maximum Amplitude Lateral (mm)	+/- 12.5 (25 total)
Maximum Amplitude Pos/Ant (mm)	+/- 5.0 (10 total)
Maximum Amplitude Surrogate (mm)	+/- 25.0 (50 total)
Editable Built-In Waveforms	sin(t), 1-2cos4(t), 1-2cos6(t), sawtooth, sharkfin
Power	110-250 VAC, 50/60 Hz

# TomoDOSE™

Diode Detector Array for TomoTherapy® Systems



## TomoTherapy System QA

- Supports routine QA, daily QA, and post-component replacement QA
- Measures entire Hi-Art beam in a single measurement, including 1 X-axis and 9 Y-axis

### Accessible Data

- Access to raw data and import water tank data for comparison with TomoDose files

### General Specifications

Detector Type	SunPoint® Diode Detectors
Detector Quantity	223 total on X and Y
Detector Spacing (mm)	X 5.0, Y 4.0, Y Off-axis 8.0
Field Size (cm)	53.0 x 9.8
Array Length (cm)	X 53.0 Y 9.8 (8.0 at ±19.0)
Y Axes Offset (cm)	±5.0, ±10.0, ±15.0, ±19.0 cm
Inherent Backscatter (g/cm²)	2.3
Active Detector Area (mm²)	0.64
Detector Volume (cm³)	0.000019
Detector Sensitivity (nC/Gy)	32.0
Detector Stability	0.5%/kGy at 6 MV
Maximum Dose Rate Limit (Gy/min)	56.0
Operating System	Windows 2000, XP 32-bit, or Vista 32-bit
Dimensions L/W/H (cm)	25.6 x 52.0 x 6.0
Weight (kg)	5.0
Number of Connection Cables	Single power/data cable

# Daily ISO Phantom

Daily Isocenter Checks Made Easy

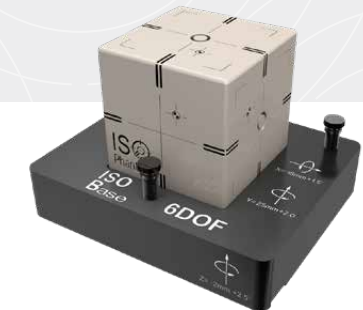

## Efficient Daily Alignment Verification

- Ensure isocenters match for imaging modalities, lasers, and surface-guided alignment systems
- Machined concentric circle targets to objectively assess setup errors, including rotations, to easily align to true isocenter
- Unique fiducials produce sharp clear images in EPID, kV and CBCT imaging

## Easy, Precise Shifting

- Available 6DOF ISO Base provides known phantom translations and rotations to check corrections made by 6DOF couches
- Manufactured with machining tolerance of ± 0.02 mm and target positioning accuracy of ± 0.1 mm

## Analysis Software

- Enables user-friendly quality control of linac isocenters by analyzing DICOM images acquired with the EPID, kV and CBCT

### Specifications

Alignment System	Engraved markings, concentric alignment circles and internal radiographic markers/targets compatible with CBCT, MV-EPID, kV imaging, 6D couches and more
Isocenter Marker	6.35 mm diameter low-Z ceramic bead
Offset Marker	6.35 mm diameter low-Z ceramic bead at a fixed offset from isocenter, for registration and repositioning
Light Field Test	Verified using integrated radiographic markers and external scribe lines corresponding to a 10 cm x 10 cm light field
Bases	6DOF ISO Base™ designed for positioning, leveling and quick calculation of complex 3D shifts of systems with integrated 6DOF robotic couch. ISO Base™ positions and levels Phantom on 3DOF (conventional) systems. Both contain integrated pixel calibration targets recognized by ISO Analyze™ software.
Dimensions	12 cm x 12 cm x 12 cm
Weight	1.7 kg



## RapidCHECK™

Automated CT-to-Density Calibration & CT Image Quality Analysis

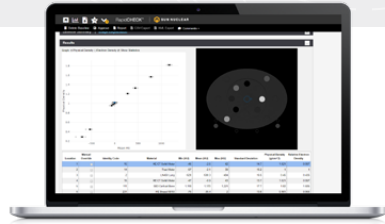

### Automate QA Workflows

- Use with **Advanced Electron Density Phantom** for faster, less-tedious calibration of CT-to-electron density tables
- Use with **CT ACR 464 Phantom** to automate image quality analysis faster analysis, trending reports, and an easily searchable permanent record
- Use with **IQphan Phantom** to quickly process CT data into results and reports

### Browser-Based Software

- Use RapidCHECK software from any browser in your clinical network
- Get results immediately, load data, and see analysis

### Specifications

Operating System	Windows 10 (Pro, Enterprise, and Educational) or Windows 11 (Pro, Education, Enterprise, Pro Education) with either Microsoft Edge or Google Chrome browsers, with at least an i3 processor, 8 GB RAM, and 10 GB of drive space
Regional Settings	US or International
Minimum Computer Specifications	Intel i3 processor; total RAM 4 GB (8 GB recommended); 10 GB of drive space; Display resolution 1280 x 1024; Color depth 32-bit
Browser	Google Chrome (recommended) or Microsoft Edge

## Advanced Electron Density Phantom

Tissue-Equivalent CT-to-Electron Density Calibration



### Automated CT-to-Electron Density Analysis

- Patented rod markers\* uniquely identify each material in a CT scan
- CT-to-density tables are automatically generated in the **RapidCHECK™** software

### Sized for Wide-Beam Applications

- Larger phantom body diameter supports evaluation of cone-beam CT and wide-beam CT scanners
- Removable section for head and small body protocols

### Superior Tissue Equivalence & Chamber Compatibility

- Meets medical standards ICRU-44 and ICRP for human tissue densities
- Constructed with Solid Water® background material
- Compatible with any ion chamber

### Specifications

In-plane Dimensions	40.0 cm (15.7 in) x 30.0 cm (11.8 in)
Depth	16.5 cm (6.3 in), up to 26.5 cm (10.2 in) with optional extension plates
Removable Head Section Diameter	20.0 cm (7.87 in)
Material	HE Energy-matched CT Solid Water® phantom material
Interchangeable Inserts	14 solid inserts plus two true water containers
Optional Inserts	Aluminum, Stainless Steel, Titanium
Available Upon Request	Extension plates, Ion Chamber conversion rod
Weight	15.5 kg (34.1 lbs)
Wheeled Case	Included
Stand	Included
Warranty	5 years

\*U.S. Patent No. 10,939,891

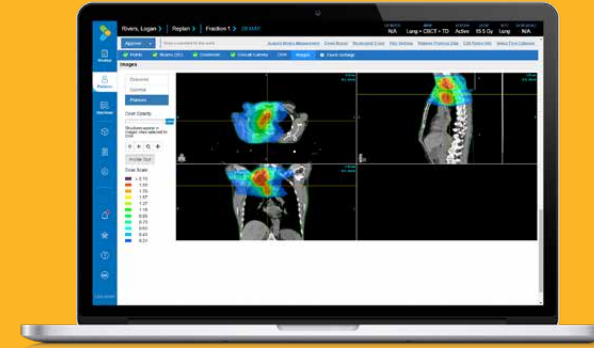

# Varian Medical Systems® Halcyon™ System & Ethos™ Therapy QA

We offer a range of independent QA solutions for these well-adopted platforms.

Learn more: [sunnuclear.com/halcyonqa](http://sunnuclear.com/halcyonqa)



Varian Medical Systems® is a registered trademark, and Varian™, Halcyon™, and Ethos™ are trademarks, of Varian Medical Systems, Inc. Sun Nuclear Corporation is not affiliated with or sponsored by Varian Medical Systems, Inc.

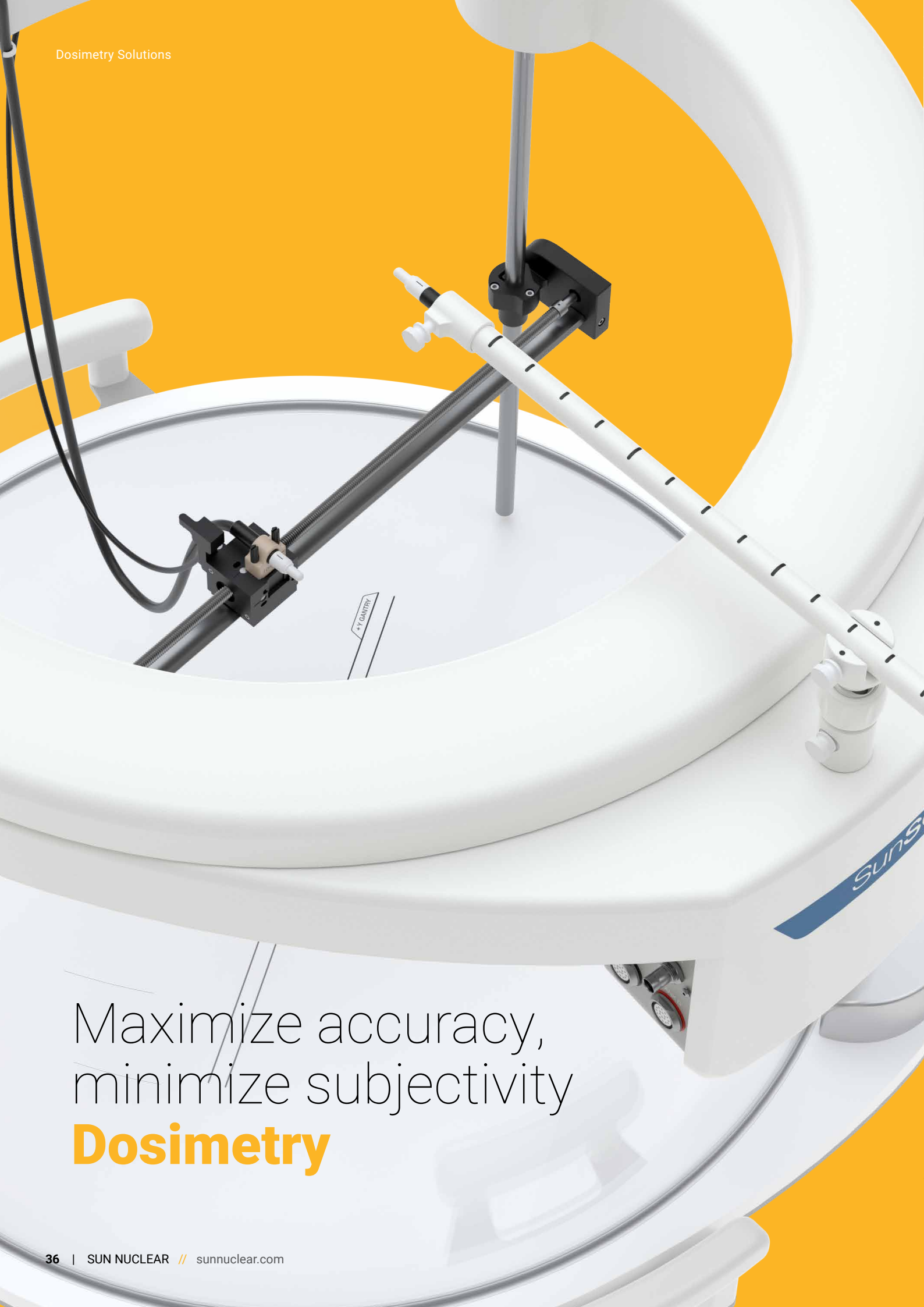

## SunSCAN™ 3D

### Next-Generation Cylindrical Water Scanning System

#### User-Centered Design

- Faster, easier commissioning and beam scanning, with SRS-class accuracy
- Unique cylindrical shape removes need for tank shifts, which take time and compromise scanning setup
- Single Setup
  - 65 cm scan range allows 40 x 40 cm field scans, even at 100 cm SSD and 40 cm depth
- Consistent Detector Orientation
  - Smallest part of the detector always measures the beam edge, minimizing stem and cable effects and water movement
- Virtual Reference Detector using Pulse Normalization permitting accurate scanning of small fields without the need of a physical reference detector

#### 7-Minute AutoSetup™

- Automatic setup in a third of the time of other tanks
- Tank is leveled and aligned, with detector positioned at water surface, in minutes
- True, physical leveling enables the most accurate scans and is achieved through a proven guided workflow

#### Intuitive Software

- New SunDOSE™ software reduces clicks to complete commissioning, and features favorite and enhanced workflow features
- AutoSetup routine guides users through tank setup



#### General Specifications

Vertical (mm)	400
Diameter (mm)	650
Ring (Degrees)	360
Motors	Encoded stepper/servo
Scanning Modes	Continuous and step
Scanning Speed Range (mm/sec)	Variable up to 20
Scanning Accuracy (mm)	0.1 throughout the 3D volume
Repeatability (mm)	0.05
Position Resolution (mm)	0.02

#### Water Tank

Thickness Wall/Bottom (mm)	13/19
Height (mm)	916
Width (mm)	736
Diameter Inner (mm)	676
Water Capacity (L)	172
Weight Empty/Full (kg)	59/194
Linac Pulse Count	Included with threshold detection

#### Software

Tank Centering	Automatic
Leveling	Automatic
Surface Detection	Automatic
TPS Export	Included

Maximize accuracy,  
minimize subjectivity  
**Dosimetry**



**“With SunSCAN 3D, in form and function, it’s clear Sun Nuclear put thought into every detail to help medical physics teams work smartly. It’s easy to set up, fill and drain. Plus, it’s light and compact for moving and storing. Above all, it offers high accuracy for confidence in your commissioning and annuals.”**

Kayhan Mohajeri, M.S., DABR,  
Medical Physicist





## Control Center with Integrated Electrometer

### Highlights

- Improved Signal to Noise Ratio for superior small signal measurements
- Dual bias control, compatible with most detectors
- Enhanced Dynamic Mode automatically adjusts to signal - no need to set gain

## SunDOSE™ Software

### Highlights

- Easily move between tasks with intuitive interface
- With visualization of all layers, users can see processing applied on each scan, and batch process similar scan types with one click
- Live Scan QA and TPS Model QA for maximum confidence in scanning data

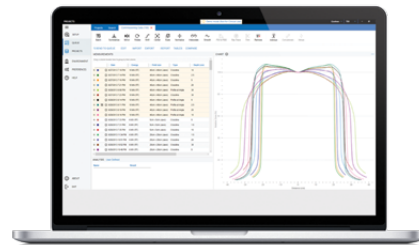

## SunSCAN™ TPR

### Highlights

- Supports Varian Medical Systems®, Elekta, Siemens and CyberKnife® delivery systems
- Less than 5-minute installation with no additional tools
- 20 cm TPR drain measurement in 2.5 minutes
- 20 cm TPR fill measurement in 3.5 minutes



## Digital Pendant

### Highlights

- Two interchangeable pendants on tank and reservoir
- Easy-to-read backlit display
- Intuitive controls for tank, lift and reservoir
- Interlock prevents accidental irradiation



## Reservoir

### Highlights

- Redesigned with half the footprint
- Dripless tank connector and self-enclosed hose avoid spills
- Water filter included



## Mini-Lift Table (MLT)

### Highlights

- Integrated Automatic Leveling Platform
  - Leveling to within <0.02 degrees
  - Centering to within <0.1mm
- Straddles linac couch ring for stability
- Fits through standard doorways; legs fold for storage
- Quick and easy disassembly for transport



## Reference Detector

### Interference-Free Dosimetry Scanning



### Small Field Annuals & Commissioning

- Linac head leakage allows the Reference Detector to obtain a reference signal during water tank scanning of photon energies
- Use with Sun Nuclear water tank for commissioning measurements of any field size
- Fully out-of-field detector is ideal for small fields

### Easy & Efficient

- Mounts to top surface of a supported linac gantry using a non-invasive dual-lock fastener
- Includes 2-meter cable with triax connector

### Specifications

Volume (cc)	39
L x W x H (mm)	125 x 105 x 15
Reference Point (mm)	2-meter cable with triaxial connector
Placement	Top surface of linac head, via dual-lock fastener

## ATOM® Phantom Family

### Versatile Dosimetry Investigation & Verification

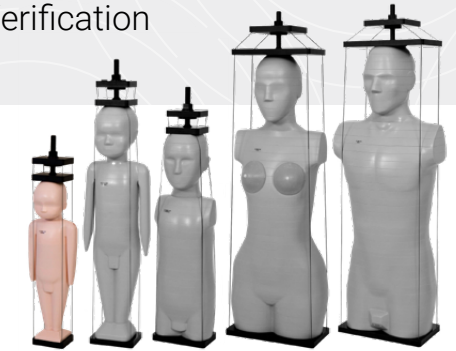

### Highlights

- Full line of anthropomorphic, cross-sectional dosimetry phantoms, consisting of five clinically relevant ages
- Uniquely designed for investigation of organ doses and whole body effective doses, as well as the verification of therapeutic radiation doses
- Produced with average soft tissue, average bone tissue, cartilage, spinal cord, spinal disks, lung, brain, and sinus tissues

### Linear Attenuation of Simulated Tissues

- Within 1% of actual attenuation for soft tissue and bone
- Within 3% for lung, from 50 keV to 15 MeV
- Lung tissue is a low-density inhale formulation equivalent to 0.2 g/cc

### Homogenous Bone

- Uses age-specific, averaged mineral density of cortical and trabecular bone ratios to create a homogenous bone, with no distinction in the anatomy
- Eases comparative Monte-Carlo calculations for dose verification
- Makes red-marrow measurements in electron equilibrium easier to obtain



## 1D SCANNER™

Accurate Point Dose & PDD Dosimetry Water Tank



DIRECT SunCHECK INTEGRATION

### Simple, Efficient Water Scanning

- Perform dosimetry measurements in water, including output factors, dose calibrations, annual, and routine QA
- Collect PDD curves with optional SunDOSE™ or SNC Dosimetry™ software and **PC Electrometer™**

### Easy, Reproducible Setup

- Single power and data cable connection
- Water surface detection feature automatically sets the dosimetry detector at the water surface

### Software

- Organize and execute groups of scans
- 1-click quantitative analysis across data sets
- Easy, searchable access to data

### Specifications

Inner Dimensions L/W/H (cm)	35.0 x 39.0 x 36.2
Exterior Dimensions L/W/H (cm)	37.6 x 40.6 x 36.8
Interior Volume	50 liters at 35 cm depth
Weight empty with arm (kg)	10.4
Arm positioning increments (cm)	0.01, 0.1, 1.0 & 10.0
Arm positioning accuracy (cm)	± 0.01; ± 0.02 for movements of 10 cm
Scan depth maximum (cm)	30.0
Operating system	Windows 10 Pro 64-bit
Number of connection cables	Single power/data cable

## PC Electrometer™

Portable, Reference-Class Electrometer



DIRECT SunCHECK INTEGRATION

### Accurate & Convenient

- Dual channel reference class electrometer for absolute dose calibration
- Available in BNC or TNC triax connectors

### Simple & Portable

- Small and lightweight for easy transport
- Simple setup with single USB and < 1-minute warm-up time

### Software

- Organize and execute groups of scans
- 1-click quantitative analysis across data sets
- Easy, searchable access to data

### Specifications

Warm Up Time	< 1.0 min
Charge Range	2 pC – 10 mC, 15 fC resolution
Current Range (Continuous)	Low 2 pA – 50 nA
Current Range (Pulsed)	0 -105 pC/pulse
Leakage Drift	±0.001 pA
Display Update Frequency(s)	500 ms
Bias Voltage	Adjustable, 0 to ±400 V
Non-linearity	± 0.1% of full scale
Long-Term Stability	< ± 0.5%
Measurement Repeatability	± 0.25% of full scale
A/C Converter	16-bit
Operating System	Windows 10 Pro 64-bit
Dimensions	10.6 x 14.8 x 4.5 cm
Weight	0.46 kg
Compatibility	SunDOSE or SNC Dosimetry software
Conformity	Reference class according to IEC 60731

## EDGE Detector™

Ultimate Small Field Detector for Precision 3D Dosimetry



### Well-Suited for Small Fields

- SunPoint® Diode Detector is 842 times smaller, and has 100 times more signal, than micro ionization chambers
- Small size ideal for accurate penumbra characterization
- Also ideal for steep gradients for fields ≤10 cm

### Compliance

- Supports compliance with TRS483 and precision dosimetry

### Specifications

Active Detection Area (mm)	0.8 x 0.80.3 from top, 4.72 from end
Diode Die Location (mm)	2.7 from side; location is indicated by cross hairs on top of the housing
Water Depth Equivalent (mm)	0.5
Housing Wall Thickness (mm)	0.13 brass
External Dimensions (mm)	3.8 x 5.5 x 38
Nominal Sensitivity (nC/Gy)	32.0
Impedance (Mohm)	>200 at 10 mV reverse bias
Output Polarity	Negative
Cable	3.4 mm dia. x 1.8 m long, triax
Cable Connector	BNC or TNC triax, or adapters upon request

## SNC125c™

Reference Class Dosimetry



### Reliable & Accurate Reference Dosimetry

- Vented, waterproof and fully guarded
- White chamber body makes visualization easy
- Reduces the convolution of high-dose gradient regions during profile and depth measurements

### Ion Chamber Highlights

- Meets IEC 60731 standards
- $k_Q$  factors available for TG-51, TRS398 and DIN 6800-2 calibrations
- Enhanced penumbra without loss of signal strength
- Optimized to work with Sun Nuclear's unique cylindrical water scanning systems
- Maintains ideal orientation during scans
- Sensitivity of a 0.125 cm<sup>3</sup> chamber and penumbra closer to a micro-chamber

### Specifications

Active Volume (cm <sup>3</sup> )	0.108
Active Length (mm)	7.05
Active Diameter (mm)	4.75
Sensitivity (nC/Gy)	3.4
Wall Material	Paint 0.05 mm PMMA 0.30 mm Graphite 0.25 mm
Electrode	0.8 mm diameter aluminum
Vented	To atmosphere through waterproof tubing
Waterproofing	Viton tubing
Polarizing Voltage	±400 V Max
Cable Length (m)	1.5
Cable Connector	TNC or BNC

## SNC350p™

Electron Reference Dosimetry



### Reliable & Accurate Reference Dosimetry

- Vented, waterproof and fully guarded
- White chamber body makes visualization easy
- Parallel-plate ion chamber is well-guarded to minimize perturbation effects for reference, field, and scanning dosimetry of therapeutic electron beams, TDD/TPS commissioning and QA

### Ion Chamber Highlights & Compliance

- Supports absolute or relative dose point measurements and PDD measurements
- Conforms to the design principles as stated by Dr. M. Roos et al. (IAEA TRS-381)
- Meets AAPM TG-51 and IAEA TRS-398 requirements for low-energy beams (<10 MeV)

### Specifications

Sensitive Volume (cm³)	0.388
Entrance Window (mm)	0.05 Paint; 1.00 PMMA; 0.02 Carbon
Reference Point (mm)	1.0 Below Window Surface
Collection Volume Height (mm)	2.0
Collector Diameter (mm)	15.6
Guard Ring Width (mm)	4.1
Polarity Effect	Within 1.000 (±) 0.01
Waterproofing	Viton tubing

### Max Dose Rate for (Gy/s)

≥ 99.5 % Saturation	5.2
≥ 99.0 % Saturation	10.4

### Max Dose Per Pulse for (mGy)

≥ 99.5 % Saturation	0.46
≥ 99.0 % Saturation	0.92

Radiation Quality	Photons Co-60 to 25 MV Electrons 5 MeV to 25 MeV
-------------------	---

Field Size (mm)	Minimum 40 x 40 Maximum 400 x 400
-----------------	--------------------------------------

Sensitive Volume (cm³)	0.388
Entrance Window (mm)	0.05 Paint

## SNC600c™

Photon & Electron Reference Dosimetry



### Reliable & Accurate Reference Dosimetry

- Vented, waterproof and fully guarded
- White chamber body makes visualization easy

### Ion Chamber Highlights

- Based on the classic Farmer Chamber design
- $k_Q$  factors available for TG-51, TRS398 and DIN 6800-2 calibrations
- Design allows use in most slab phantoms
- Reference class performance (IEC 60731) allows for use in X-ray and electron reference dosimetry protocols - TG-51 and TRS-398

### Specifications

Active Volume (cm³)	0.6
Active Length (mm)	22.7
Active Diameter (mm)	6.1
Sensitivity (nC/Gy)	20
Wall Material (mm)	Paint 0.05, Graphite 0.43
Energy Range	Co-60 - 25 MV; V9 MeV - 25 MeV
Electrode (mm)	1.1 diameter aluminum
Vented	To atmosphere through waterproof tubing
Waterproofing	Viton tubing
Buildup Cap (mm)	4.5
Polarizing Voltage	±400 V Max
Length (m)	1.5
Cable Connector	TNC or BNC

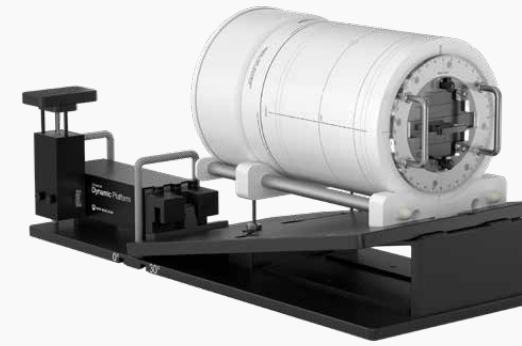

# Motion QA

Meet the exacting requirements of Motion QA with our comprehensive range of products designed for this purpose.

Learn more: [sunnuclear.com/motion](http://sunnuclear.com/motion)

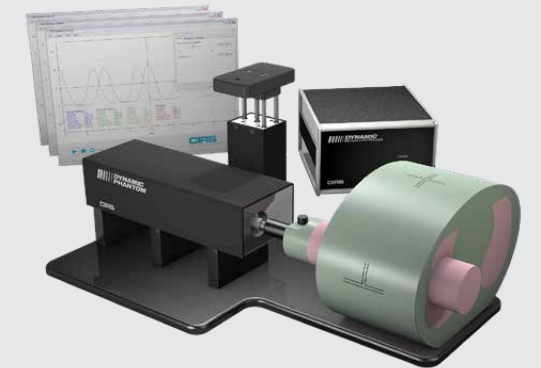
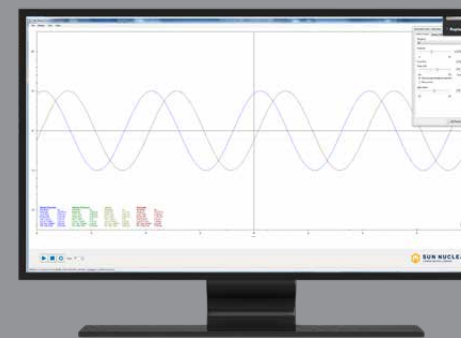





Industry-standard solutions  
and innovations for  
**Diagnostic QC**

## Doppler Ultrasound Phantoms

Reproducible System Velocity Testing



### Comprehensive QA & Testing

- Determine maximum signal penetration, channel isolation, and flow rate readout accuracy
- Doppler flow and B-Mode QA test systems
- Meet ACR, ECR, and AIUM QA requirements
- **Doppler 403™ Flow Phantom** ideal for abdominal flow measurements
- **Mini-Doppler 1430™ Flow Phantom** ideal for cardiology and musculoskeletal applications

### Unparalleled Tissue Mimicking

- Blood-mimicking fluid ultrasonically similar to human tissue, with an electronic flow of 1550 m/s
- Patented High Equivalency Gel\* (HE Gel™) offers tissue mimicking for evaluating image uniformity, detecting dead transducer elements, and assessing maximum penetration depth

### Specifications

HE Gel™ Multi-Frequency Tissue-Mimicking Material	Included
Composite Film Scanning Surface	Included
Vessels (2)	5 mm inner diameter; 1 horizontal at 2 cm depth, 1 diagonal at 40° from 2 to 16 cm deep (403) 4 mm inner diameter; 1 horizontal at 2 cm depth, 1 diagonal at 35° from 2 to 9 cm deep (1430)
Flow Rates	Customizable, constant and pulsatile
Blood Mimicking Fluid	Speed of Sound 1550 +/- 10 m/s
Targets	Strings, cysts, greyscale, resolution groups
Dimensions (Case)	28 H x 30.5 W x 22 cm (403) 20 H x 23 W x 15.2 cm (1430)
Weight	8.34 kg (403) 4.6 kg (1430)

\*U.S. Patent No. 6,352,860

## B-Mode Ultrasound Phantoms

Training & Compliance Ultrasound Testing



### Comprehensive Offerings

- Comprehensive Ultrasound QA solutions from Sun Nuclear for training through compliance and more
- Sun Nuclear patented\* HE Gel™ and Zerdine® Hydrogel provide multi-frequency, high quality, reproducible images

### Comprehensive QA Test Coverage

- Meet ACR, AIUM, AAPM and IEC TS 62736:2016 requirements
- Test across the entire frequency range (2 - 18 MHz)
- **Model 40GSE** Multi-purpose, multi-tissue phantom with elastography and dual attenuation zones
- **Sono403™**: Multi-purpose phantom ensures accurate screening, diagnosis and monitoring
- **Model ATS 539**: Multi-purpose phantom of durable urethan rubber construction
- **Model ATS 570**: Multi-purpose, endoscopic phantom with curved scan surface and endocavity well for enhanced testing of curved probes and endo probe

### Basic QA Test Coverage

- Provide support for compliance tests; limited ability to support other recommended QA tests
- Test across the entire frequency range (2 - 18 MHz)
- **Model ATS 539**: General purpose, low-cost QA solution for compliance tests
- Dedicated Ultrasound image uniformity phantoms

See [sunnuclear.com](http://sunnuclear.com) for a full listing of Ultrasound QA solutions, including Small Parts and Special Purpose phantoms and detailed specifications.

## CT ACR 464 Phantom

### Multi-Modality CT Accreditation



#### Comprehensive CT Testing

- Test positioning and alignment accuracy, CT number accuracy, slice thickness, low contrast detectability, image resolution and uniformity, spatial resolution, and inter- and intra-plane distance measurement accuracy
- Meet AAPM TG-66 requirements

#### Proven & Versatile Design

- Made of the original Solid Water® Zero HU formulation
- Works with **RapidCHECK™** software to automate CT image quality testing or analysis with the SunCHECK(R) Platform
- Optional Phantom Body Ring and Extensions available

See [sunnuclear.com](http://sunnuclear.com) for specifications.

## IQphan™

### Comprehensive CT Image Quality Phantom

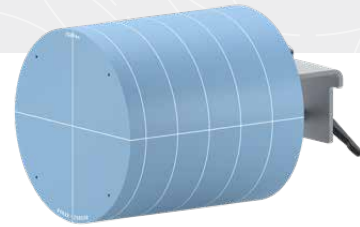

#### Comprehensive CT QA – All in One Phantom

- Perform QA across CT imaging systems, from sophisticated diagnostic scanners to cone beam to on-board radiotherapy systems
- Use with **RapidCHECK™** Image Quality Analysis software for exacting CT imaging quality testing, with quick, consistent analysis

#### Modular Testing Support

- High-Contrast Resolution Module features high-resolution line pairs, large 3D patterns that are easy to visualize, and robust data analysis in **RapidCHECK** software
- Slice Thickness & Geometric Evaluation Module with multiple wire-ramp materials and diameters enable analysis of slice thickness on range of scanners -- from diagnostic CT to CBCT and MVCT
- Low-Contrast Detectability Module provides a low-contrast test covering radiation therapy systems and diagnostic CT
- Uniformity Module supports assessment of noise and uniformity in HE CT Solid Water
- HU Module tests the consistency of known HU materials and measures the effective energy of the scan

See [sunnuclear.com](http://sunnuclear.com) for specifications.

## Multi-Energy CT Phantom

### Comprehensive Spectral Testing, Tissue Equivalence



#### Comprehensive Testing of Scanner Performance

- Test efficacy of clinical protocols over an expanded range of material concentrations for multi-energy analysis
- Compare consistency and stability across scanners
- Expanded range of testing to exceed draft AAPM Task Group 299 requirements

#### Automated Material Discrimination

- Solid rods represent iodine, calcium, blood, adipose, and more
- Patent-pending rod markers enable automated analysis

#### Specifications

In-Plane Dimensions	40.0 cm (15.7 in) x 30.0 cm (11.8 in)
Depth	16.5 cm (6.3 in), up to 26.5 cm (10.2 in) with extension plates
Removable Head Section Diameter	20.0 cm (7.87 in)
Material	HE CT Solid Water® phantom material
Interchangeable Inserts	27 solid inserts plus 1 true water container, each tagged with a CT-visible rod identification code
8 HE Iodine Inserts with Variable Concentrations	Concentrations of 0.2, 0.5, 1.0, 2.0, 5.0, 10.0, 15.0, and 20.0 mg/mL
3 Iodine Inserts with Variable Diameters	5.0 mg/mL concentration at diameters of 2.0, 5.0, and 10.0 mm
8 HE Calcium Inserts	Concentrations of 0, 5, 10, 20, 50, 100, 200, and 300 mg/mL
3 Blood [iron] Inserts	Blood-mimicking material at relative electron densities of 1.03, 1.07, and 1.10
2 Blood [iron] with Iodine Inserts	Blood-mimicking material plus iodine at 2.0 and 4.0 mg/mL
3 Tissue-Mimicking Inserts	High-Equivalency Brain, High-Equivalency Adipose, High-Equivalency CT Solid Water
Weight	15.5 kg (34.1 lbs)
Wheeled Case	Included
Stand	Included

## Mercury 4.0 Phantom

### Advanced CT Performance Assessment



#### Characterize Advanced CT Features

- Address performance and effectiveness of Automatic Exposure Control/Tube Current Modulation
- Evaluate image quality for Iterative Reconstruction
- Meet AAPM TG-233 requirements

#### CT Protocol Optimization

- 5-tiered sections reflect range of patient sizes, and enable size-dependent image quality evaluation
- Software analysis, featuring imQuest software available from Duke University

#### Specifications

Material	Polyethylene
Diameter	16.0, 21.0, 26.0, 31.0, and 36.0 cm
Length	52.0 cm
Contrast Materials	HE CT Solid Water®, Bone Mimicking Material, Polystyrene, 10 mg/mL Iodine, and Air
Resolution Wedge	HE CT Solid Water® phantom material
Software Analysis	Works with imQuest software, available from Duke University
Included	Wheeled Case and Stand

## RapidCHECK™ Software

### Automated CT-to-Density Calibration & CT Image Quality Analysis

#### Automate QA Workflows

- Use with **IQphan Phantom** to quickly process CT data into results and reports
- Use with **Advanced Electron Density Phantom** for faster, less-tedious calibration of CT-to-electron density tables
- Use with **CT ACR 464 Phantom** for automation of image quality analysis, trending reports, and an easily searchable permanent record

See p.34 to learn more.

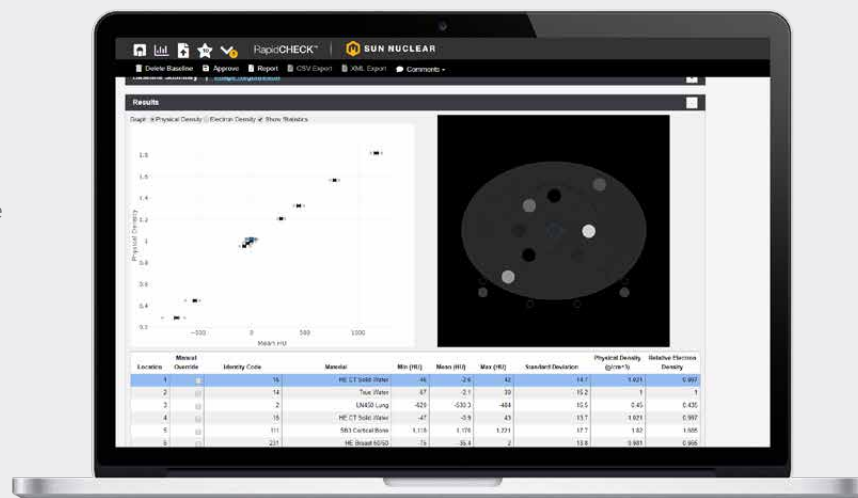



## CTDI Phantoms

Computed Tomography Dose Index Phantom



### Compliance Maintenance

- Measure absorbed dose and monitor scanner output for Dose Index QA
- Meet AAPM TG-66 requirements
- 2 and 3-piece configurations available
- Nested modules adapt the phantom to the size required by user protocol

### Specifications

Material	Polymethyl-Methacrylate (PMMA/Acrylic)
Density	1.19 g/cm <sup>3</sup>
Alignment Markings	Etched lines centered on all three planes
Module	Dimensions (OD x Length)
Adult Body	32 cm x 14.5 cm
Adult Head/Pediatric Body	16 cm x 14.5 cm
Pediatric Head (Model 468-BHP only)	10 cm x 14.5 cm
Chamber Ports Diameter	1.31 cm

## CT Perfusion Phantom

Optimize Imaging & Perfusion Protocols

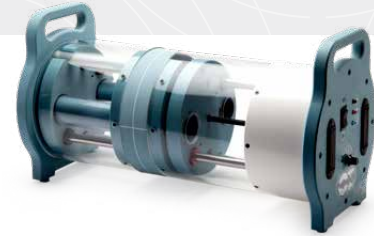

### Consistent, Optimized CT Perfusion Programs

- Ensure your CT scanner and perfusion software are providing consistent results by benchmarking perfusion rates and time-attenuation curves
- Use the dose port to optimize imaging and perfusion protocols

### Specifications

Covers and housings	PVC, Acrylic
Dosimetry Port	Standard CT Pencil Chambers
Central Scan Disk	High Equivalency (HE) Brain Mimicking Material
Artery and Vein Rods	16 discrete sections of blood and contrast simulating materials to mimic arterial flow and delayed venous flow rates following a contrast bolus injection
Brain Tissue Rods (Qty 2)	16 discrete sections of brain tissue to mimic tissue uptake rates following a contrast bolus injection
Velocity settings (mm/second)	1.31, 1.50, 1.75, 2.10, 2.63 +/- 2%
Perfusion Rod Travel Distance	10.5 cm (4.1 in)
Power	8 AA batteries (included)
Weight	13.6 kg (29.9 lbs)

## Stereotactic Needle Biopsy Phantom

Enabling Critical Testing & Training



### Highlights

- For use in localization accuracy test per ACR's stereotactic breast biopsy accreditation program
- Use upon system installation or repair, to ensure accurate needle placement
- Anthropomorphic shape allows accurate simulation of breast compression
- Re-usable - will not dry out, or leak when punctured; Masses can be biopsied multiple times
- 11 dense masses in three sizes; Two microcalcification clusters
- Compatible with standalone and add-on stereotactic biopsy systems

### Specifications

Dimensions	10 cm x 16.6 cm x 5 cm (6.5" x 2.5" x 4")
Phantom Weight	1.0 lb. (0.4 kg)
Phantom Volume	530 cc
Material	Polyurethane

## Multi-Modality Breast Biopsy and Sonographic Trainer

A Versatile Tool for Shaping Best Practices



### Highlights

- Designed to train users in aspects of breast imaging and image-guided interventional procedures - X-ray, Ultrasound, MRI
- Includes cystic and dense lesions embedded within breast background
  - Half of dense lesions spherical with embedded 100-300 micron microcalcification, half with spiculated shape
  - Calcifications serve as useful markers for image registration between modalities
- Features patent-pending Z-Skin™ membrane to simulate skin, providing protection from desiccation even after multiple sessions

### Specifications

Tray Dimensions	26 cm x 23 cm x 7.5 cm (10" x 9" x 3")
Breast Size	500 cc (14 cm x 11 cm at base, 8 cm high)
Total Weight	1 lb. (0.4 kg)
Membrane Material	Z-Skin™ elastomer
Background Material	Zerdine®, white
Cystic Masses	Qty: 5-10
Dense Masses	Material: Zerdine®

## AAPM CT Performance Phantom

Meet AAPM Report #1 Guidelines

### Highlights

- Comprehensive Testing: Measures ten CT performance parameters, aligning with AAPM Report #1 guidelines
- Versatile Design: Includes variable-size cavities for contrast tests and interchangeable inserts for dose measurements
- Precision Tools: Features inserts for assessing CT number linearity, resolution, and slice thickness
- Durable and Portable: Made from PMMA cast tubing, lightweight and easy to transport

See [sunnuclear.com](http://sunnuclear.com) for specifications.

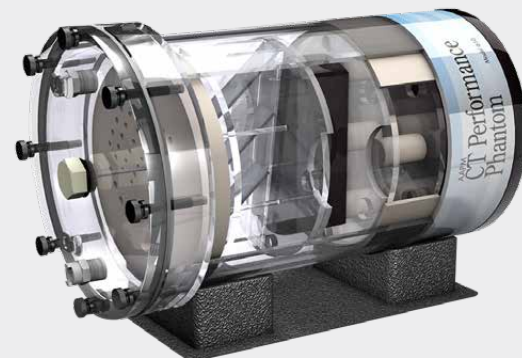

## Image-Guided Abdominal Biopsy Phantom

Image-Guided Training and Demonstration

### Highlights

- Minimal needle tracking- Z-skin™ fat layer and softer gel provide better self-healing properties
- Re-usable
  - Will not dry out, or leak when punctured
  - Masses can be biopsied multiple times
- Improve performance of freehand abdominal biopsies
- Validate automated biopsy systems

See [sunnuclear.com](http://sunnuclear.com) for specifications.



## DBT QC Phantom

Thorough Tomosynthesis System Performance Testing

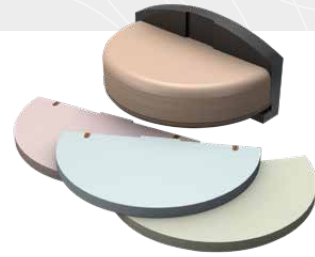

### Comprehensive Digital Testing

- Acceptance testing, daily and routine QC
- Tests image quality and stability of DBT systems
- Consistent, repeatable targets in homogeneous background
- Optional complex background provides clinically relevant challenge for target detection
- Slab configurations provide range of thicknesses with or without targets
- Developed to meet developing requirements of EUREF and AAPM TG-245

### Specifications

Overall Dimensions	127 mm x 80 mm x 100 mm
Individual Slab Dimensions	6 Slabs: 110 mm x 180 mm x 10 mm; 1 Slab: 115 mm x 180 mm x 10 mm (support slab); 1 Slab: 110 mm x 180 mm x 5 mm, semicircular shape
Phantom Weight	1.62 kg (3.55 lbs)
Materials	BR50/50, BRSW5050
Set Includes	4 Solid Homogeneous Slabs 1 cm thick; 1 Solid Homogeneous Slabs 0.5 cm thick; 3 Target Homogeneous Slabs 1 cm thick; 1 Positioning Holder with Magnetic Fixation

## Mammo FFDM™ Phantom

Full Field Digital Mammography

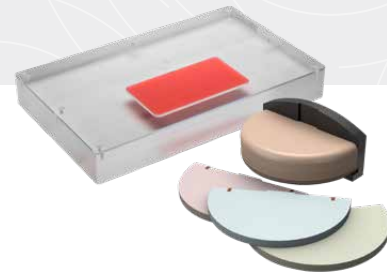

### Ensure Optimal FFDM Performance

- Evaluate artifacts over the entire detector with a single image
- Meet ACR, MSQA and EUREF requirements
- Test objects designed and located per ACR specifications, and reduced backscatter and equalized attenuation
- Meets ACR 2018 Digital Mammography Quality Control Manual requirements

### Specifications

Materials	Wax and acrylic equivalent to 4.2 cm thick compressed breast tissue
Nylon Fibers	6
Specks	6 Groups, Glass Spheres
Masses	6
Dimensions (L x W x H)	31.0 ± 0.1 x 19 ± 0.1 x 4.1 ± 0.03 cm
Dimensions: Wax Insert (L x W x H)	12.98 (+0, -0.04) x 6.98 (+0, -0.04) x 0.7 ± 0.02 cm
CNR Cavity Depth	0.1 ± 0.005 cm
CNR Diameter	2.0 ± 0.05 cm
Compensator	9 mil Polyvinylidene Chloride
Case	Optional custom hard-sided case, with 1-year warranty

## Mammo 156™ & 156D Stereo™ Phantoms

Digital Mammography System QC, Biopsy & Localization



### Measure & Monitor Digital Mammography Systems

- Phantoms simulate the radiographic characteristics of compressed breast tissue
- Detect objects from 0.20 to 1.00 mm
- Monitor signal-to-noise, resolution and image quality
- Meet ACR and MSQA requirements
- Hang Mammo 156D on biopsy system detector during rotation

### Specifications

Materials	Wax and acrylic equivalent to 4.2 cm thick compressed breast tissue. 50% adipose & 50% glandular Mammo 156D fibers, specks and masses follow ACR specifications.
Nylon Fibers (Fibrils)	6 (156)
Nylon Fibers (monofilament) DIA (mm)	0.40, 0.54, 0.74, 0.93 (156D)
Micro-calcifications	5 Groups (156)
Micro-calcifications (Aluminum Oxide) DIA (mm)	0.20, 0.24, 0.32, 0.54 (156D)
Masses	5 (156)
Masses DIA (mm)	0.25, 0.50, 0.75, 1.00 (156D)
Dimensions (L x W x H)	10.2 x 10.8 x 4.5 cm (156) 6.7 x 6.8 x 6.1 cm (156D)
Case	Optional soft-sided case with foam insert, with 1-year warranty

## Mammo 3D™ Performance Kit

Digital Mammography System QC



### Acceptance Testing for 3D Tomosynthesis Systems

- Includes PMMA plates, spacers, aluminum plates and foils, steel plates and customized test tools
- Meet IEC Protocol 601223-3-6, EUREF/EFOMP 1.03 (Tomosynthesis), & German DIN 6868-14 requirements

### Specifications

Standard Test Plate	1 - 320 x 260 x 45 mm
10 mm PMMA Plate	7 - 320 x 260 x 10 mm
15 mm PMMA Plate	1 - 320 x 260 x 5 mm
2 mm PMMA Plates	7 - 40 x 20 x 2 mm
10 mm PMMA Spacers	2 - 180 x 15 x 10 mm
30 mm PMMA Spacers	2 - 180 x 30 x 30 mm
Geometric Distortion & Z-Resolution Phantom	1 - 320 x 260 x 5 mm
Custom Hard Case	Included

### Aluminum Plates & Foils

2 mm Aluminum Plate	1 - 100 x 100 x 2 mm
0.2 mm Aluminum Foil Sheet	1 - 10 x 10 x 0.2 mm
0.1 mm Aluminum Foil Sheets	8 - 100 x 100 x 0.1 mm

### Steel Plates

3 mm Stainless Steel Plate	1 - 320 x 260 x 3 mm
MTF Edge Tool	1 - 120 x 60 x 0.6 mm

### Wire, Spacers, X-ray Rulers

25 micron Tungsten Wire (cm)	100
Polystyrene Foam Spacers	5 - 240 x 180 x 20 mm
1 mm scale X-ray Rulers	4 - +2.5 to -5 cm

## Mammo CESM™ Phantom

QC for Contrast Enhanced Spectral Mammography

### Independently Verify Beam Qualities

- Stack of modules supports a variety of tests across a range of iodine concentrations and breast glandularity
- Blocks can be arranged to represent compressed breast for small to large patients

See [sunnuclear.com](http://sunnuclear.com) for specifications.

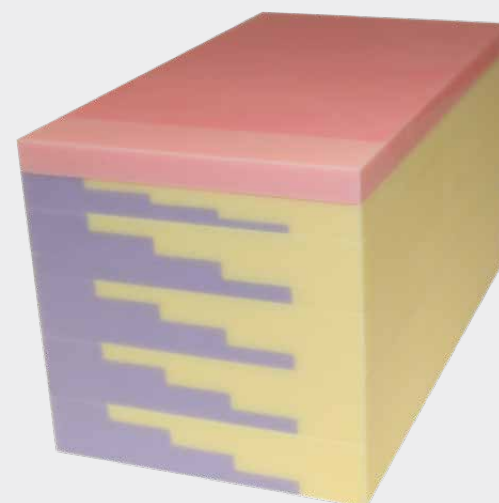





Learn more >>

## Instadose®VUE

### Wireless Dosimeter

The new Instadose®VUE wireless dosimeter from Mirion Dosimetry Services revolutionizes how radiation exposure monitoring is performed, with unprecedented flexibility and convenience to ensure safety in the workplace. Harnessing Bluetooth® Low Energy Technology, the InstadoseVUE dosimeter enables wearers to capture dose reads on-demand, anytime and anywhere.

With programmable calendar features, scheduling automatic dose reads is easy, simplifying dose management even further. Experience radiation exposure monitoring like never before with the InstadoseVUE – where advanced technology meets user-friendly functionality.

### Exposure Reporting and Feedback at Your Fingertips

- Configurable automatic, calendar-set dose read intervals programmed to the reporting schedule you select (weekly, monthly, quarterly, or custom)
- Perform on-demand dose reads anytime
- Access to current and historical exposure data online via any internet-enabled device
- Prompt risk mitigation through on-demand data access, enabling earlier intervention

### Reduce Costs & Waste

- Employees keep their assigned dosimeters, eliminating the need to collect and redistribute dosimeters
- When staff changes occur, badges can be efficiently assigned or reassigned
- Reduces environmental impact by decreasing the frequency of manufacturing and processing dosimeters

**Supporting Solutions**  
from the broader Mirion portfolio

As part of Mirion, Sun Nuclear is pleased to offer proven solutions from our Mirion Medical and Mirion Technologies product lines.

The following pages highlight Mirion innovations now available directly from your Sun Nuclear representative. These include our newest wireless dosimeter, as well as range of Health Physics offerings for effective radiation monitoring in healthcare environments.

Not available for sale in all markets



## RDS-Med™ Radiation Survey Meter

### High Sensitivity for Patient & Staff Safety

- Detects a wide range of ionizing radiation, including gamma and X-rays
- Displays multiple radiation levels and types simultaneously
- Complies with IEC 60846-1 and ANSI 42.17A standards

### Wide Probe Compatibility

- Connects to external alpha, beta, and neutron probes
- Compatible with GMP-12/GMP-25 probes and Mirion CSP™ probe family

### Intuitive, User-Friendly

- Clear display and straightforward user interface for quick assessment of radiation level
- Ergonomic, lightweight design
- Included battery cover and belt clip

### Specifications

Detector	RDS-Med - One energy-compensated GM tube
IEC Energy Range	48 keV to 1.8 MeV
Dose Rate Measurement Range	0.05 $\mu$ Sv/h to 100 mSv/h (5 $\mu$ rem/h to 10 rem/h)
IEC Dose Rate Measurement Range	0.3 $\mu$ Sv/h to 100 mSv/h (0.03 mrem/h to 10 rem/h)
Dose Measurement Range	0.1 $\mu$ Sv to 10 Sv (0.01 mrem to 1000 rem)
Dose Rate Linearity	-15% to +22% 0.3 $\mu$ Sv/h to 0.1 Sv/h (0.03 mrem/h to 10 rem/h)

See [sunnuclear.com](http://sunnuclear.com) for specifications.

## RDS-Med™ Radiation Monitoring Area Monitor

### Enhanced Radiation Safety in Medical Environments

- Provides immediate and clear alerts to maintain radiation safety standards
- Critical for protecting healthcare professionals and patients from ionizing radiation exposure

### Modular and Configurable

- Designed for fixed installation in environments needing reliable, continuous radiation monitoring
- Transparent cover for easy viewing of internal and optional external probe measurements
- RDS-Med is easily removed for use as a hand-held survey meter, for shielding surveys and to identify local hot spots
- Modular signaling sets with visual and audible alarms (105 dBA siren) for clear and visual alerts of beam on or off

### Robust & Reliable

- Designed for continuous operation with a 85-240 VAC power supply and backup internal batteries
- Offers area monitoring via LAN using WRM2™ data transmission protocol and web-based remote monitoring
- IP65 rated with protection caps, ensures durability and resistance to environmental factors
- Optional neutron and Beta modules are available

See [sunnuclear.com](http://sunnuclear.com) for mechanical and electrical characteristics.

## DMC 3000™ Personal Electronic Dosimeter

### Advanced Radiation Detection and Safety

- Precise, reliable detection of X-rays and gamma radiation for medical professionals in radiological environments
- Configurable alarms and alert settings for immediate notification when exposure exceeds user-defined thresholds

### Durable & User-Friendly

- Compact, lightweight, and robust with a user-friendly interface and clear display for easy operation and readability
- Rugged, high-impact polycarbonate-ABS case that is easy to decontaminate and alcohol resistant
- Supports up to 12 months of battery life under typical use and up to 3000 hours in continuous mode
- Waterproof (IP67), shock, vibration, and drop resistant

### Flexible and Versatile Use

- Can be used standalone in smaller clinics or integrated into a larger healthcare facility's ecosystem
- Compatible with additional modules for enhanced detection capacity and connectivity features, such as Bluetooth and neutron detection
- Supports incremental dose estimates from higher exposure procedures
- Optional neutron and beta modules are available

See [sunnuclear.com](http://sunnuclear.com) for mechanical, electrical and environmental characteristics.

## ConnectStudio™ Connectivity Management Software

### Stronger Exposure Monitoring and Supervision

- Visual displays of dose and rate supports radiation exposure reduction efforts
- Efficient and easy pairing with DMC 3000 with Bluetooth Module, and RDS-Med Survey Meter and Area Monitor
- Manages connections and reconnections automatically in case of lost signal

### Operational Efficiency & Compatibility

- Operational telemetry supervision at a glance
- Facilitates quick actions in case of radiation alarms or pre-alarms
- Compatible with Windows 10 and Android systems, supporting a range of devices including PCs and tablets with integrated NFC reader





**Sun Nuclear  
Headquarters (US)**

**Phone**  
+1 (321) 259-6862

**Address**  
3275 Suntree Blvd,  
Melbourne, FL 32940

**Sun Nuclear  
Virginia (US)**

**Phone**  
+1 (757) 855-2765

**Address**  
900 Asbury Ave  
Norfolk, VA 23513

**Sun Nuclear  
GmbH**

**Phone**  
+49 6102-50495-00

**Address**  
Gutenbergring 67 A  
22848  
Norderstedt, Germany

**SunServices™  
Center - EMEA**

**Phone**  
+31 20 399 90 41

**Address**  
Verlengde Poolseweg 36  
4818 CL Breda, The Netherlands



**SUN NUCLEAR**

A MIRION MEDICAL COMPANY

©2025 Mirion Technologies, Inc. or its affiliates. All rights reserved. Sun Nuclear, the Sun Nuclear logo, and other trade names of Sun Nuclear products listed herein are registered trademarks or trademarks of Mirion Technologies, Inc. or its affiliates in the United States and other countries. Third party trademarks mentioned are the property of their respective owners. All Rights Reserved. All data used is best available at time of publication. Data is subject to change without notice.

MKTG-3494 Sun Nuclear Product Solutions Brochure